

Project _____
 Item _____
 Quantity _____
 CSI Section 11400
 Approval _____
 Date _____

NOBLE HT-180



Standard Features

- Sani-Sure™ feature ensures proper rinse water temperature
- Multi-cycle timer (Extra Heavy, Heavy, Medium, Normal)
- Specially designed stainless steel nozzles provide superior cleaning action
- 17-1/4" (438 mm) door opening accepts 18" (457 mm) trays
- Interchangeable wash/rinse arms screw out for simple cleanup
- Auto-fill/auto-start
- Door switch
- Delime/manual wash switch
- Vent fan control
- Low watt density electric wash tank heater
- Hi-limit thermostat and low water protection
- Top mounted controls for ease of operation
- Adjustable bullet feet
- Uses standard 20" X 20" (508 mm X 508 mm) racks
- Front dress panel
- Detergent/rinse additive signal connection fuse box
- Self-draining stainless steel pump
- Built-in 70° F (38.9° C) rise booster heater is standard
- Large scrap basket

Mandatory Specs

Specify voltage _____

Options

- 480V Electrical
- Single Phase
- Drain Quench System
- Scaltril
- Water Hammer Arrestor
- Pressure Regulator
- Flanged Feet
- False Panel
- Door Interlock

Accessories

- 36-Compartment Rack
 - 4-1/8" tall (105 mm)
 - 5-5/8" tall (143 mm)
 - 7" tall (178 mm)
- Combination Rack
- Peg Rack

Specifications

Uses 0.89 gallons (3 liters) of water per rack
 Total automatic (normal) cycle - 57 seconds
 58 racks per hour (normal) cycle
 1 HP Wash Pump Motor
 Single point connections for all utilities

Field convertible from straight through to corner and vice versa

Field convertible from 3-phase to single-phase and vice versa

Durable stainless steel construction



Intertek



Intertek



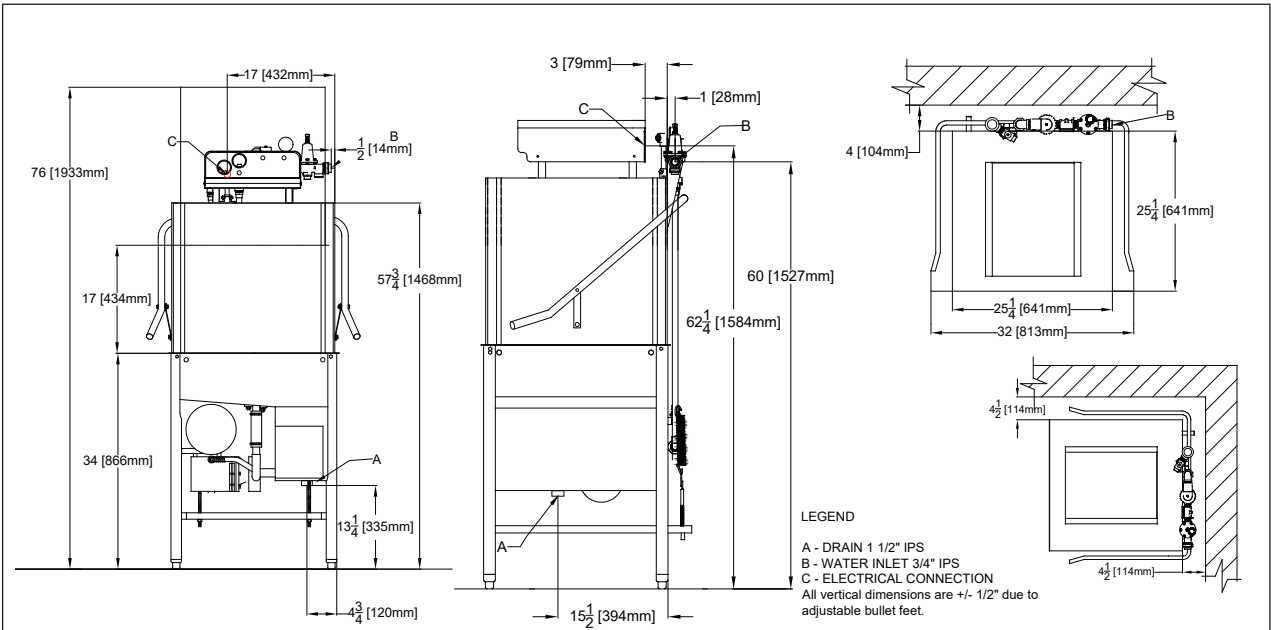

MODEL NO.	MACHINE DIMENSIONS				DRAIN HEIGHT	SHIPPING INFORMATION				
	HEIGHT	WIDTH	DEPTH	DRAIN HEIGHT		WEIGHT	CLASS	CUBE	HEIGHT	WIDTH
NOBLE HT-180	64-3/8" (1635 mm)	25-1/4" (641 mm)	25-1/4" (641 mm)	13-1/4" (335 mm)	263 lbs (120 kg)	200	58.15 cu. ft.	72.5" (1842 mm)	33" (839 mm)	42" (1067 mm)

DIMENSION REQUIREMENTS	
Wall Clearance (minimum)	4" (102 mm)
Standard Table Height	34" (864 mm)
Inside Clearance	17-1/4" (438 mm)
Machine Height with Door Open	76" (1933 mm)

WATER REQUIREMENTS	
Inlet Temperature	70°F (38.9°C) Rise
Gallons per Hour	52 gal (197 L)
Gallons per Rack	.89 gal (3 L)
Waterline Size IPS (minimum)	1/2"
Drainline Size IPS (minimum)	1- 1/2"
Flow Pressure (PSI)	10
Wash Tank Capacity	8 gal (30 L)
Booster Tank Capacity	3 gal (11 L)

OPERATING CAPACITY				
Racks per Hour	Normal 58	Medium 30	Heavy 20	Extra Heavy 12
OPERATING CYCLE (seconds)	Wash	Rinse	Dwell	Total Cycle
Normal	40	13	4	57
Medium	100	13	4	117
Heavy	160	13	4	177
Extra Heavy	280	13	4	297

OPERATING TEMPERATURES	
Wash (minimum)	150° F (66° C)
Rinse (minimum)	180° F (82° C)

WASH PUMP MOTOR		
Wash Pump Motor Horsepower		1 HP
	Volts	KW
Electric Wash Tank Heater	208V	4.1
	230V	5.0
	460V	5.0
Electric Rinse Tank Heater - 70°F (38.9°C) Rise	208V	10.5
	230V	12.9
	460V	12.9

APPROXIMATE LOAD AMPS	
Power Supply	AMPS
208V/60HZ/1PH	75.8
208V/60HZ/3PH	46.3
230V/60HZ/1PH	83.6
230V/60HZ/3PH	50.7
460V/60HZ/3PH	24.1

HOW TO SPECIFY: NOBLE HT-180