

# TECHNICAL MANUAL

INSTALLATION MANUAL FOR EXPORT UNITS  
SERVICE MANUAL FOR DOMESTIC UNITS

FOR JACKSON MODELS:

Delta<sup>®</sup> 115

Delta<sup>®</sup> 1200



REVISION	REVISION DATE	MADE BY	APPLICABLE ECN	DETAILS
A	10-27-08	CW		Initial release of manual.
B	11-10-08	GS	8074	Revised Drawings.
C	06-05-09	ARL	90605-1430-MD	Updated electrical schematic.
D	02-10-10	RLC	091106-1526-CW	Corrected part number on page 36
E	02-14-12	RLC	QOF 386	Corrected view on pg 35 to show correct position of mounting plate, Corrected item 14 on pg 40 from 05930-011-61-65 to 05700-003-60-13
F	05-21-12	RLC	QOF 386	Release of 14 RPM peri-pump assembly
G	03-21-13	RLC	QOF NDB-219	Update manufacturer name.
H	06-09-14	MHH	QOF 386	Corrected part # of item 14 on pg. 30. Added note to pg. 35 about placement of part #'s 36 & 31.
I	09-15-14	KAP	N/A	Updated Jackson Logo
J	01-30-15	KAP	QOF-386	Updated part list on page 42
K	08-07-15	KAP	N/A	Updated detergent squeeze tube P/N. Updated & labeled rinse aid & sanitizer squeeze tubes pg's 33-34.
L	10-08-15	KAP	N/A	Updated item #9, Curtain Rod P/N to 05700-003-60-38 on pg. 32.
M	11-19-15	JH	ECN 8336	Added Delta 115 and associated schematics, etc.

## GLASSWASHER SERIES

Delta 115 = 24" Glasswasher, 115v

Delta 1200 = 24" Glasswasher, 208v

Model: \_\_\_\_\_

Serial No.: \_\_\_\_\_

Installation Date: \_\_\_\_\_

Service Rep. Name: \_\_\_\_\_

Phone No.: \_\_\_\_\_

---

## TABLE OF CONTENTS

---

<b><u>SECTION</u></b>	<b><u>DESCRIPTION</u></b>	<b><u>PAGE</u></b>
<b>I.</b>	<b>SPECIFICATION INFORMATION</b>	<b>2</b>
	Specifications	3
<b>II.</b>	<b>INSTALLATION/OPERATION INSTRUCTIONS</b>	
	Installation Instructions	5
	Electrical Connections	6
	Detergent Control	7
	Chemical Dispensing Equipment	8
	Operating Instructions	9
<b>III.</b>	<b>PREVENTATIVE MAINTENANCE</b>	<b>10</b>
<b>IV.</b>	<b>TROUBLESHOOTING</b>	<b>12</b>
<b>V.</b>	<b>SERVICE PROCEDURES</b>	
	Replacing the Chemical Feeder Pump Motor	17
	Wash Tank Heater Replacement	20
	Thermostat Replacement	24
	Wash Motor Replacement	26
<b>VI.</b>	<b>PARTS SECTION</b>	
	Control Box Assembly - Delta 115	30
	Control Box Assembly - Delta 1200	32
	Outer Shell Assembly	34
	Chemical Feeder Pump Assembly	36
	Rinse Assembly	38
	Wash System - Delta 115	40
	Wash System - Delta 1200	42
	Conveyor and Drive System	44
	Door Assembly	46
<b>VII.</b>	<b>ELECTRICAL DIAGRAM</b>	
	Glasswasher 115 Volt, 60 Hertz, Single Phase	49
	Glasswasher 208-230 Volt, 60 Hertz, Single Phase	50

---

**SECTION 1:  
SPECIFICATION INFORMATION**

---

## SECTION 1: SPECIFICATION INFORMATION

### SPECIFICATIONS

	<u>Delta 115</u>	<u>Delta 1200</u>
<b>OPERATING CAPACITY (RACKS/HOUR)</b>		
GLASSES PER HOUR	1200	1200
<b>OPERATING CYCLE (SECONDS)</b>		
TOTAL CYCLE TIME	120	120
<b>TANK CAPACITY (GALLONS)</b>		
	3.0	3.0
<b>WASH PUMP CAPACITY</b>		
WASH PUMP	55 GPM	55 GPM
<b>TEMPERATURES</b>		
WASH---°F (MINIMUM)	120	130
RINSE---°F (MINIMUM)	75	75
<b>WATER REQUIREMENTS</b>		
INLET TEMPERATURE	120°F	130°F
GALLONS PER HOUR	10.0	10.0
WATER LINE SIZE NPT (Minimum)	1/2"	1/2"
DRAIN LINE SIZE NPT (Minimum)	1-1/2"	1-1/2"
FLOW PRESSURE P.S.I.	20 ± 5	20 ± 5
MINIMUM CHLORINE REQUIRED (PPM)	50	50
<b>ELECTRICAL REQUIREMENTS</b>		
WASH PUMP MOTOR HORSEPOWER	1/10	1/10

**NOTE: Typical Electrical Circuit is based upon (1) 125% of the full amperage load of the machine and (2) typical fixed-trip circuit breaker sizes as listed in the NEC 2002 Edition. Local codes may require more stringent protection than what is displayed here. Always verify with your electrical service contractor that your circuit protection is adequate and meets all applicable national and local codes. These numbers are provided in this manual simply for reference and may change without notice at any given time.**

#### Delta 115

<u>VOLTS</u>	<u>PH</u>	<u>HZ</u>	<u>RINSE HEATER RATINGS</u>	<u>TOTAL AMPS</u>	<u>TYPICAL ELECTRICAL CIRCUIT</u>
115	1	60	120/1.3KW	15.9A	20A

#### Delta 1200

<u>VOLTS</u>	<u>PH</u>	<u>HZ</u>	<u>RINSE HEATER RATINGS</u>	<u>TOTAL AMPS</u>	<u>TYPICAL ELECTRICAL CIRCUIT</u>
208	1	60	220V/3KW	15A	15A
230	1	60	220V/3KW	15A	15A

**NOTE: Always refer to the machine data plate for specific electrical and water requirements. The material provided on this page is for reference only and may be subject to change without notice.**

**SECTION 1: SPECIFICATION INFORMATION**  
**MACHINE DIMENSIONS**

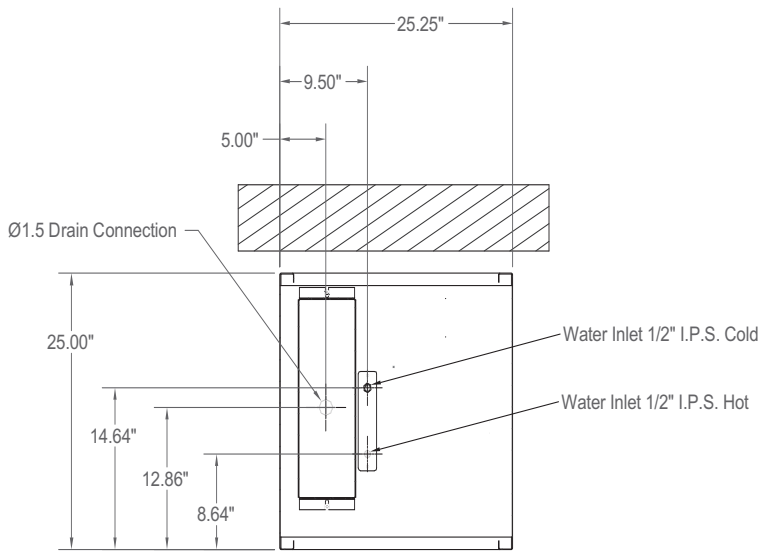

SECTION B-B  
 SCALE 0.09 : 1

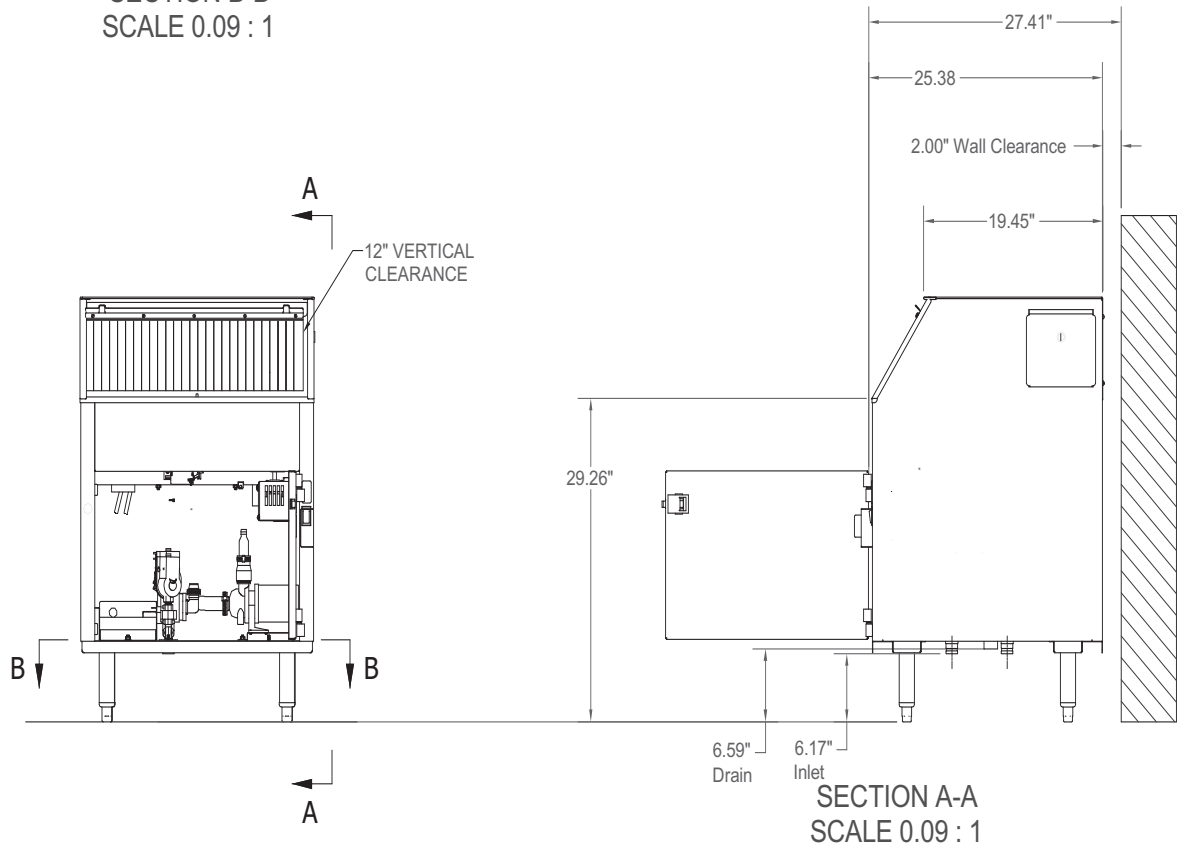

SECTION A-A  
 SCALE 0.09 : 1

---

**SECTION 2:  
INSTALLATION/OPERATION  
INSTRUCTIONS**



## SECTION 2: INSTALLATION/OPERATION INSTRUCTIONS

### INSTALLATION INSTRUCTIONS

**VISUAL INSPECTION:** Before installing the unit, check the container and machine for damage. A damaged container is an indicator that there may be some damage to the machine. If there is damage to both the container and machine, do not throw away the container. The dishmachine has been inspected and packed at the factory and is expected to arrive to you in new, undamaged condition. However, rough handling by carriers or others may result in there being damage to the unit while in transit. If such a situation occurs, do not return the unit to Jackson; instead, contact the carrier and ask them to send a representative to the site to inspect the damage to the unit and to complete an inspection report. You must contact the carrier within 48 hours of receiving the machine. Also, contact the dealer that sold you the unit.



Packaged unit should be visually inspected for damage.

**UNPACKING THE DISHMACHINE:** Once the machine has been removed from the container, ensure that there are no missing parts from the machine. This may not be obvious at first. If it is discovered that an item is missing, contact Jackson immediately to have the missing item shipped to you.



Use a pry bar and mallet to remove the hold-down blocks.



Remove any protective plastic prior to installation.

**LEVEL THE DISHMACHINE:** The dishmachine is designed to operate while being level. This is important to prevent any damage to the machine during operation and to ensure the best results when washing ware. The unit comes with adjustable bullet feet, which can be turned using a pair of channel locks or by hand if the unit can be raised safely. Ensure that the unit is level from side-to-side and from front-to-back before making any connections.

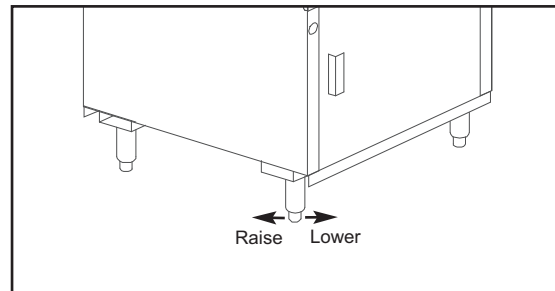

**PLUMBING THE DISHMACHINE:** All plumbing connections must comply with all applicable local, state, and national plumbing codes. The plumber is responsible for ensuring that the incoming water line is thoroughly flushed prior to connecting it to any component of the dishmachine. It is necessary to remove all foreign debris from the water line that may potentially get trapped in the valves or cause an obstruction. Any valves that are fouled as a result of foreign matter left in the water line, and any expenses resulting from this fouling, are not the responsibility of the manufacturer.

**CONNECTING THE DRAIN LINE:** The Delta glasswashers have a gravity drain (2" NPT connection). All piping from the machine to the drain must be a minimum 2" NPT and must not be reduced. There must also be an air gap between the machine drain line and the floor sink or drain. If a grease trap is required by code, it should have a flow capacity of 5 gallons per minute (GPM).

## SECTION 2: INSTALLATION/OPERATION INSTRUCTIONS

### ELECTRICAL CONNECTIONS

**WATER SUPPLY CONNECTION:** Ensure that you have read the section entitled “PLUMBING THE DISHMACHINE” above before proceeding. Cold water supply must be a minimum of 75°F with a capacity of 180 gallons per hour at 8-12 PSI flow to the glasswasher. Hot water supply must be a minimum of 130°F with a capacity of 10 gallons per hour at  $20 \pm 5$  PSI flow pressure. Incoming hot and cold water service connection (supplied by customer) must be a 1/2" pipe size minimum with shut-off valve. Install the water supply line (1/2" pipe size minimum) to the dishmachine using copper pipe. It is recommended that a water shut-off valve be installed in the water line between the main supply and the machine to allow access for service.

In areas where the water pressure fluctuates or is greater than the recommended pressure, it is suggested that a water pressure regulator be installed.

Do not confuse static pressure with flow pressure. Static pressure is the line pressure in a “no flow” condition (all valves and services are closed). Flow pressure is the pressure in the fill line when the fill valve is opened during the cycle.

It is also recommended that shock absorbers (not supplied with the Delta units) be installed in the incoming water lines. This prevents line hammer (hydraulic shock), induced by the solenoid valves as they operate, from causing damage to the equipment.

**PLUMBING CHECK:** Slowly turn on the water supply to the machine after the incoming fill line and the drain line have been installed. Check for any leaks and repair as required. All leaks must be repaired prior to placing the machine in operation.

**ELECTRICAL POWER CONNECTION:** Electrical and grounding connections must comply with the applicable portions of the National Electrical Code ANSI/NFPA 70 (latest edition) and/or other electrical codes. Disconnect electrical power supply and place a tag at the disconnect switch to indicate that you are working on the circuit.

The dishmachine data plate is located on the right side of the door. Refer to the data plate for machine operating requirements, machine voltage, total amperage load, and serial number.

To install the incoming power lines, remove the electrical box cover. This will require taking a phillipshead screwdriver and removing the two (2) screws at the bottom corners and lifting up and off. Let the cover rest against the plumbing assembly. Install conduit from the underside of machine to the hole in the rear of electrical box below terminal block and ground lug. Install the service wires (L1 & L2) to the appropriate terminals as they are marked on the terminal block.

Install the grounding wire into the lug provided. Tighten the connections. It is recommended that “DE-OX” or another similar anti-oxidation agent be used on all power connections.

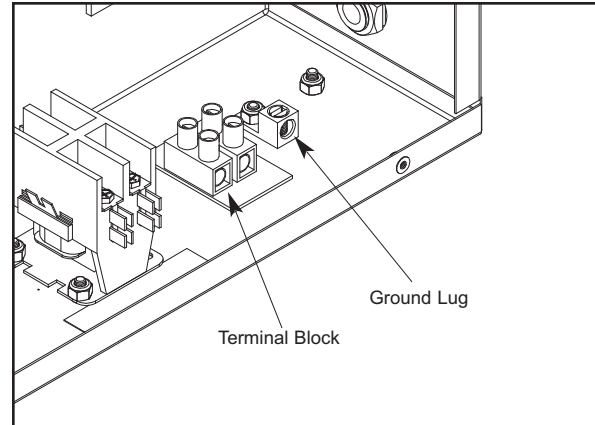

**VOLTAGE CHECK:** Ensure that the power switch is in the OFF position and apply power to the dishmachine. Check the incoming power at the terminal block and ensure it corresponds to the voltage listed on the data plate. If not, contact a qualified service agency to examine the problem. Do not run the dishmachine if the voltage is too high or too low. Shut-off the service breaker and mark it as being for the dishmachine. Advise all proper personnel of any problems and of the location of the service breaker. Replace the electrical box cover and tighten down the screws.

---

## SECTION 2: INSTALLATION/OPERATION INSTRUCTIONS

### DETERGENT CONTROL

Detergent usage and water hardness are two factors that contribute greatly to how efficiently your dishmachine will operate. Using detergent in the proper amount can become, in time, a source of substantial savings. A qualified water treatment specialist can tell you what is needed for maximum efficiency from your detergent, but you should still know some basics so you'll understand what they are talking about.

First, you must understand that hard water greatly effects the performance of the dishmachine. Water hardness is the amount of dissolved calcium and magnesium in the water supply. The more dissolved solids in the water, the greater the water hardness. Hard water works against detergent, thereby causing the amount of detergent required for washing to increase. As you use more detergent, your costs for operating the dishmachine will increase and the results will decrease. The solids in hard water also may build-up as a scale on wash and rinse heaters, decreasing their ability to heat water. Water temperature is important in removing soil and sanitizing dishes. If the water cannot get hot enough, your results may not be satisfactory. This is why Jackson recommends that if you have installed the machine in an area with hard water, that you also install some type of water treatment equipment to help remove the dissolved solids from the water before it gets to the dishmachine.

Second, hard water may have you adding drying agents to your operating cycle to prevent spotting, when the real problem is deposited solids on your ware. As the water evaporates off of the ware, the solids will be left behind to form the spotting and no amount of drying agent will prevent this. Again, using treated water will undoubtedly reduce the occurrences of this problem.

Third, treated water may not be suitable for use in other areas of your operation. For instance, coffee made with soft water may have an acid or bitter flavor. It may only be feasible to install a small treatment unit for the water going into the dishmachine itself. Discuss this option with your qualified water treatment specialist.

Even after the water hardness problems have been solved, there still must be proper training of dishmachine operators in how much detergent is to be used per cycle. Talk with your water treatment specialist and detergent vendor and come up with a complete training program for operators. Using too much detergent has as many detrimental effects as using too little. The proper amount of detergent must be used for the job. It is important to remember that certain menu items may require extra detergent by their nature and personnel need to be made aware of this. Experience in using the dishmachine under a variety of conditions, along with good training in the operation of the machine, can go a long way in ensuring your dishmachine operates as efficiently as possible.

Certain dishmachine models require that chemicals be provided for proper operation and sanitization. Some models even require the installation of third-party chemical feeders to introduce those chemicals to the machine. Jackson does not recommend or endorse any brand name of chemicals or chemical dispensing equipment. Contact your local chemical distributor for questions concerning these subjects.

Some dishmachines come equipped with integral solid detergent dispensers. These dispensers are designed to accommodate detergents in a certain-sized container. If you have such a unit, remember to explain this to your chemical distributor upon first contacting them.

As explained before, water temperature is an important factor in ensuring that your dishmachine functions properly. The data plate located on each unit details what the minimum temperatures must be for either the incoming water supply, the wash tank, and the rinse tank, depending on what model of dishmachine you have installed. These temperatures may also be followed by temperatures that Jackson recommends to ensure the highest performance from you dishmachine. However, if the minimum requirements are not met, your dishes will most likely not be cleaned or sanitized. Remember, a dish can look clean, but it may not be sanitized. Instruct your dishmachine operators to observe the required temperatures and to report when they fall below the minimum allowed. A loss of temperature can indicate a much larger problem such as a failed heater or it could also indicate that the hot water heater for your operation is not up to capacity and a larger one may need to be installed.

There are several factors to consider when installing your dishmachine to ensure that you get the best possible results from it and that it operates at peak efficiency for many years. Discuss your concerns with your local chemical distributor and water treatment specialist before there is a problem.

---

## SECTION 2: INSTALLATION/OPERATION INSTRUCTIONS

### CHEMICAL DISPENSING EQUIPMENT

#### TO PREPARE PUMPS FOR OPERATION

Delta Glasswashers are supplied with detergent, rinse additive, and sanitizer dispensing chemical feeder pumps. Locate the open ends of the chemical tubes with the tube stiffeners and place each one in the appropriate container.

- A. **Red** Tubing = **Detergent**
- B. **Blue** Tubing = **Rinse Aid**
- C. **White** Tubing = **Sanitizer**

#### PRIMING CHEMICAL FEEDER PUMPS

Chemical feeder pumps need priming when the machine is first installed, when chemicals are replenished, or if for some reason the chemical lines have been removed and air is allowed to enter.

1. Verify that the proper chemical tube stiffener inlet is in the proper container.
2. Use the push buttons on the right side of control box to prime each pump.
3. To prime the pumps, hold the push buttons until chemical can be observed exiting the pump.
4. Detergent is dispensed as required during the wash tank fill. The amount of detergent may need to be increased or decreased depending on water quality and type of detergent. It is adjusted by turning the potentiometer on the speed control board clockwise to increase, counter-clockwise to decrease.
5. Rinse additive is dispensed proportionally into the final rinse water line. The amount of rinse aid may need to be adjusted depending on water hardness and results. It is adjusted by turning the potentiometer on the speed control board clockwise to increase, counter-clockwise to decrease.
6. Sanitizer (either chlorine or iodine) is dispensed proportionally into the final rinse water line. The amount of sanitizer may need to be adjusted depending on concentration and the type of sanitizer used. It is adjusted by turning the potentiometer on the speed control board clockwise to increase, counter-clockwise to decrease.



7. **WARNING:** Some of the chemicals used in dishwashing may cause chemical burns if they come in contact with your skin. Wear appropriate protective gear when handling these chemicals. If you do come in contact with these chemicals, flush the area with fresh water.

***This equipment is not recommended for use with deionized water or other aggressive fluids. Use of deionized water or other aggressive fluids will result in corrosion and failure of materials and components. Use of deionized water or other aggressive fluids will void the manufacturer's warranty.***

---

## SECTION 2: INSTALLATION/OPERATION INSTRUCTIONS

### OPERATING INSTRUCTIONS

#### TO FILL MACHINE WITH WATER:

1. Remove wash tank strainer and place overflow stopper into fitting at the bottom of the wash tank.
2. Open incoming water shut-off valves on cold and hot water lines.
3. Place the power switch to the "FILL" position; machine will automatically fill to the correct level.
4. Check water level; it should be near the top of the overflow stopper.
5. Replace wash strainer.

#### TO RUN THE MACHINE:

1. After filling with water, turn the power switch to the "ON" position; the rack will automatically begin to rotate.
2. Place glasses on the rack.
3. When the glasses have completed the cycle, the paddle switch will be activated, turning off the water flow and conveyor rack.
4. Remove the clean glasses which are against the paddle switch.
5. The rack will begin to rotate again.

#### SHUTDOWN AND CLEANING OF THE MACHINE:

1. Ensure that all ware placed on the rack is able to complete the cycle and is cleaned prior to moving the power switch to the "OFF" position. Shut-off the water supply to the unit.
2. Remove the drain boards, rack cylinder, and rack. Clean before reinstalling into the machine.
3. Remove the sump and drain tank strainers. Clean completely before reinstalling into the machine.
4. Remove the stand pipe by grasping by the handle and removing it from the drain tank. Clean before reinstalling into the machine.



**CAUTION: Water in the drain tank may be hot! Allow the water to cool-down and always remove the stand pipe through the use of the handle. Never place your hand in the water within the drain tank.**

5. Remove the curtains and wash using a mild soap and rinse with clear water. Allow to dry completely before reinstalling into the machine.
6. Remove the wash and rinse arms. Inspect them for clogged or obstructed nozzles. Remove end caps and flush the inside of the wash and rinse arms with clean water. Reinstall end caps when completed.
7. Wipe-out the inside of the tub, removing any and all debris.
8. Reinstall all components previously removed after they have been allowed to dry.
9. Remove, clean, and reinstall upper (wash) and lower (drain) strainers.

---

## **SECTION 3: PREVENTATIVE MAINTENANCE**

---

## SECTION 3: PREVENTATIVE MAINTENANCE

### PREVENTATIVE MAINTENANCE

---

The dishmachines covered in this manual are designed to operate with a minimum of interaction with the operator. However, this does not mean that some items will not wear-out in time. Jackson highly recommends that any maintenance and repairs not specifically discussed in this manual should be performed by **QUALIFIED SERVICE PERSONNEL ONLY**. Performing maintenance on your dishmachine may void your warranty if it is still in effect, so if you have a question or concern, do not hesitate to contact Jackson.

There are many things that operators can do to prevent catastrophic damage to the dishmachine. One of the major causes of component failure has to do with prescrapping procedures. A dishmachine is not a garbage disposal; any large pieces of material that are put into the machine will remain in the machine until they are either broken-up (after spreading out on your ware) or physically removed. Strainers are installed to help catch debris, but they do no good if they are clogged. Have operators regularly inspect the pan strainers to ensure (1) that they are free of soil and debris and (2) they are laying flat in the tub.

When cleaning out strainers, do NOT beat them on waste cans. The strainers are made of metal and can be forgiving; but once severe damage is done, it is next to impossible for the strainer to work in the way it was designed to. Wipe-out strainers with a rag and rinse under a faucet if necessary. For stubborn debris, a toothpick should be able to dislodge any obstructions from the perforations. Always ensure that strainers are placed back in the machine before operation and that they lay flat in the tub.

You may wish to also refer to the page entitled "Detergent Control" in order to learn more about how your water hardness will affect the performance of your machine. Hard water makes dishmachines work harder and decreases efficiency.

Again, it is important to remind operators that trying to perform corrective maintenance on the dishmachine could lead to larger problems or even cause harm to the operator. If a problem is discovered; secure the dishmachine using proper shut-down procedures as listed in this manual and contact Jackson.

Some problems, however, may have nothing to do with the machine itself and no amount of preventative maintenance is going to help. A common problem has to do with temperatures being too low. Verify that the water temperatures coming to your dishmachine match the requirements listed on the machine data plate. There can be a variety of reasons why your water temperature could be too low and you should discuss it with Jackson to determine what can be done.

By following the operating and cleaning instructions in this manual, you should get the most efficient results from your machine. As a reminder, here are some steps to take to ensure that you are using the dishmachine the way it was designed to work:

1. Ensure that the water temperatures match those listed on the machine data plate.
2. Ensure that all strainers are in place before operating the machine.
3. Ensure that all wash and/or rinse arms are secure in the machine before operating.
4. Ensure that drains are closed/sealed before operating.
5. Remove as much soil from glasses by hand as possible before loading into racks.
6. Do not overfill racks.
7. Ensure that glasses are placed upside down in the rack.
8. Ensure that all chemicals being injected to machine have been verified as being at the correct concentrations.
9. Clean-out the machine at the end of every workday as per the instructions in the manual.
10. Always contact Jackson whenever a serious problem arises.
11. Follow all safety procedures, whether listed in this manual or put forth by local, state, or national codes/regulations.

---

# **SECTION 4: TROUBLESHOOTING**



---

## SECTION 4: TROUBLESHOOTING

### COMMON PROBLEMS



**WARNING:** Inspection, testing, and repair of electrical equipment should only be performed by a qualified service technician. Many of the tests require that the unit have power to it and live electrical components be exposed. **USE EXTREME CAUTION WHEN TESTING THE MACHINE.**

**Problem: Dish machine will not run, no voltage at wash relay terminals L1 and T1.**

1. Electrical power not installed to machine, service (main) power disconnect off. Ensure electrical wiring is run to machine and service (main) disconnect is on.
2. Branch circuit breaker tripped or fuse is blown. Reset or replace as required. Have an electrician check machine amp draw if problem keeps occurring.
3. Loose or broken connection to dish machine. Tighten, replace, or repair as required.

**Problem: Machine cycles continuously.**

1. Limit switch actuator is loose or has fallen off. Reassemble/bend metal lever if necessary.
2. Faulty limit switch. Replace switch.

**Problem: Machine will not fill, other functions work.**

1. No water supply to machine. Ensure that water is hooked-up properly to machine and that it is turned on.
2. Faulty Hot Water solenoid valve diaphragm or coil. Replace diaphragm and clean-out valve. Measure continuity on coil, if there is none, replace the coil.
3. Faulty float switch. Ohm out the switch to ensure that upper and lower floats are working. If not, check float wiring to see if it is correct; if so, replace float.

**Problem: Machine fills continuously even with no power to the dish machine.**

1. Solenoid valve jammed/stuck in the open position. Check diaphragm and coil, replace as required.
2. Faulty float switch. Ohm out the switch to ensure that upper and lower floats are working. If not, check float wiring to see if it is correct; if so, replace float switch.

**Problem: Wash motor does not run, other functions work.**

1. Loose wire connection to limit switch or relay. Tighten wires.
2. Faulty pump motor. Replace pump motor.
3. Mechanical binding in the pump. If motor has correct incoming voltage, and the overload is tripping, repair or replace the pump.

**Problem: Wash motor does not run; other functions work.**

1. High or low voltage problem. Check voltage at motor and at power terminal block. Ensure it meets the electrical voltage specifications for the dish machine.
2. Faulty limit switch. Replace limit switch.

**Problem: Wash motor runs continuously.**

1. Wash relay welded closed. Turn machine off. If wash relay does not release, replace.

**Problem: Low water pressure.**

1. Water level is too low. Ensure that incoming water line pressure meets the requirements on dish machine data plate.
2. Wash arms clogged. Remove wash arms and clean.
3. Obstruction in pump housing. Disassemble and clear.
4. O-ring at wash tank drain cut or missing. Replace.

---

## SECTION 4: TROUBLESHOOTING

### COMMON PROBLEMS

---

**Problem: Low wash water pressure at wash arm spray nozzles.**

1. Pump impeller worn or broken. Replace pump.
2. Clogged jets in wash arms. Clean out wash arms.
3. Float stuck on float switch. Remove, clean, and reinstall float switch.
4. Water level too low in the wash tank. Ensure that the incoming water line flow pressure meets the requirements on the dish-machine data plate.

**Problem: Machine keeps tripping service breaker.**

1. Power supply shorted to ground. Check for loose wires/burned connection. Replace or repair as required.
2. Pump impeller jammed. Disassembly and remove obstruction.
3. Wash pump motor faulty. Check motor voltage and amp draw.
4. Service breaker too small. Replace with correctly sized breaker.

**Problem: Machine will not hold water.**

1. Drain stopper not in place. Set drain stopper correctly in drain.
2. Drain fitting O-ring cut or missing. Replace O-ring.
3. Drain stopper bent or deformed. Replace.

**Problem: Sanitizer pump runs continuously.**

1. Shorted prime switch. If there is not line voltage between BLACK/YELLOW and ORANGE/BLUE wires to prime switch, replace.
2. Faulty speed control board. Check operation of board. If not working properly, replace.

**Problem: Sanitizer pump does not run during cycle, but runs when primed. Even when turntable is off.**

1. Loose or broken wire. Replace or tighten.
2. Faulty speed control board. Check operation of board. If not working properly, replace.
3. Faulty prime switch. Check continuity through each pole of the speed control board. If it fails, replace the speed control board.

**Problem: Prime switch does not activate sanitizer pump.**

1. Faulty prime switch. With the prime switch in the prime position, check for voltage between BLACK/YELLOW and ORANGE/BLUE wires. If line voltage, replace switch.
2. Loose wire to prime switch. Tighten wire connection.

**Problem: Sanitizer pump doesn't run during cycle or through prime switch.**

1. Loose motor terminal wires. Tighten connections.

**Problem: Sanitizer pump doesn't run during cycle or through prime switch.**

1. Faulty sanitizer pump motor. If you read line voltage at the sanitizer motor terminals during the sanitizer feed cycle, replace the motor.
2. Faulty prime switch. Check the continuity through each pole of the switch. If faulty, replace the speed control board.

**Problem: Detergent not feeding, rinse aid feeds okay.**

1. Faulty speed control board. Check operation of board. If not working properly, replace.
2. Defective hose or squeeze tube. Replace hose or squeeze tube as needed.
3. Machine not in fill mode. Normal operation.

---

## SECTION 4: TROUBLESHOOTING

### COMMON PROBLEMS

---

**Problem: Rinse aid pump not feeding, detergent feeds okay.**

1. Faulty speed control board. Check operation of board. If not working properly, replace.
2. Defective hose or squeeze tube. Replace hose or squeeze tube as needed.

**Problem: Wash heater does not work. (NOTE: push wash heater contactor bar down and take amperage reading. Amps should be correct as stated on the dish machine data plate).**

1. If no amp draw, check wash heater for continuity. If open or shorted, replace the heater. If closed, replace the heater contactor.
2. Wash heater relay will not energize (no voltage at contactor coil). Check for continuity at wash thermostat. If open, replace.
3. Low voltage problem. Check incoming voltage to ensure it is what the data plate calls for.

---

## **SECTION 5: SERVICE PROCEDURES**

---

## SECTION 5: SERVICE PROCEDURES

### REPLACING THE CHEMICAL FEEDER PUMP MOTOR

---

Jackson glasswasher machines come equipped with chemical feeder pumps to ensure proper ware washing results. Occasionally, the motors operating these pumps may need replacing to maintain optimum performance.

Jackson offers all of the repair parts necessary for performing this task.

The instructions provided here are for maintenance personnel only. Unauthorized persons should not attempt any of the steps contained in these instructions.



**CAUTION:** many of the instructions and steps within this document require the use of tools. Only authorized personnel should ever perform any maintenance procedure on the dish-machine!

#### **PREPARATION**

1. Power must be secured to the unit at the service breaker. Tag or lock-out the service breaker to prevent accidental or unauthorized energizing of the machine.
2. Ensure that incoming water to the machine is secured either by use of a shut-off valve or disconnecting the incoming water line.
3. The unit must be drained completely with the drain stopper removed.

#### **TOOLS REQUIRED**

The following tools will be needed to perform this maintenance evolution:

- Phillipshead Screwdriver
- Needle-nose Pliers
- Wire Cutters
- Wire Strippers
- Crimping Tool

#### **TIME REQUIRED**

It is estimated that it will take (1) person thirty minutes per motor to perform this task, not including all of the items indicated in the section entitled "PREPARATION."

#### **IMPORTANT NOTES**

1. Read these instructions thoroughly before attempting this maintenance task. Become familiar with the parts and what actions need to be taken. This will save time in the long run!
2. These instructions show steps on only (1) of the three motors. However, the steps are the same for each one.

#### **STEPS**



Removing the screws for the electrical box cover.

1. Remove the front door.

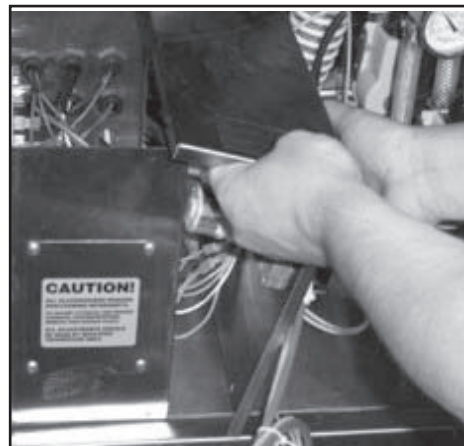

Removing the electrical box cover.

2. Remove the electrical box cover with the phillipshead screw-driver.
3. The cover must be laid down close to the control box because of the attached wires. Be careful not to yank out or damage any of the wires as you move the cover.
4. Determine which motor you wish to replace, or which one you wish to start with. Trace the wires leading from the motor to its corresponding prime switch. Trace the other wire from the motor to determine where it is connected.
5. With the needle-nose pliers, remove the motor wire from the prime switch, being careful not to damage the prime switch in the process. (If the prime switch is damaged, it will need to be replaced. Refer to the parts section of the technical manual for part numbers.)

---

## SECTION 5: SERVICE PROCEDURES

### REPLACING THE CHEMICAL FEEDER PUMP MOTOR (CONTINUED)

---

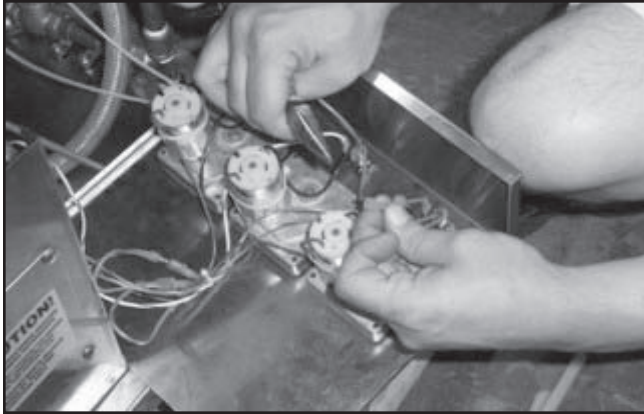

Removing the priming switch wire

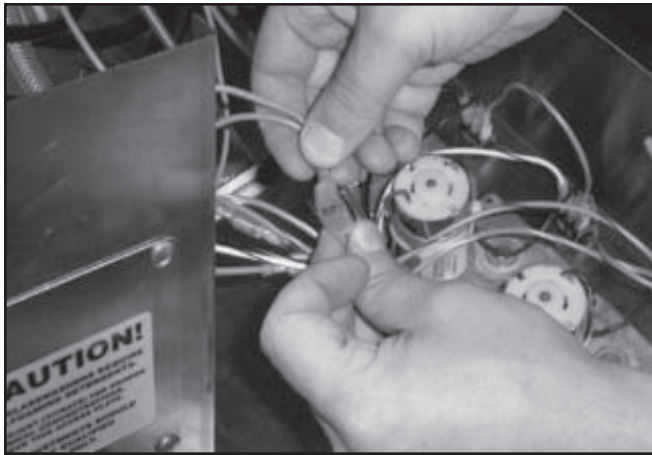

Unhooking motor power wire

6. Turn the cover over and using the phillipshead screwdriver, remove the cover to the pump requiring a motor change.

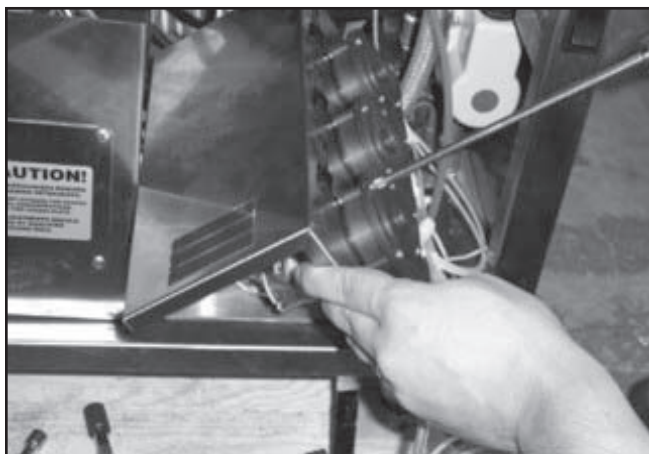

Removing the pump front cover screws.

7. With the cover removed, gently pull out the rubber tube from inside the pump.

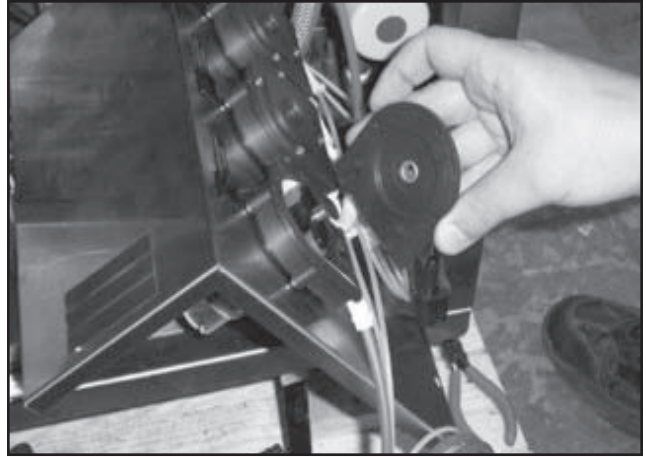

Removing the front cover.

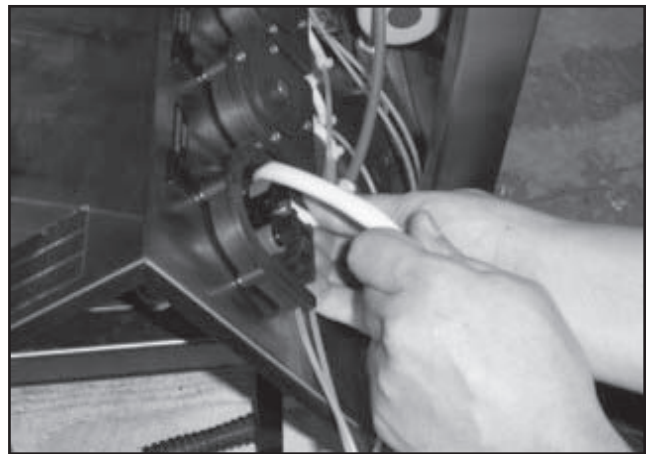

Pulling the rubber tube out of the pump.

8. Remove the roller by pulling it off of the shaft.

9. Using the phillipshead screwdriver, remove the four mounting screws for the motor.

10. Once the screws are removed, the motor should drop away.

11. Cut away any tie-wraps that are holding the power wires and remove the motor.

12. Take your new motor and attach new terminals to the wires as required.

13. Remount the motor to the pump.

---

## SECTION 5: SERVICE PROCEDURES

### REPLACING THE CHEMICAL FEEDER PUMP MOTOR (CONTINUED)

---

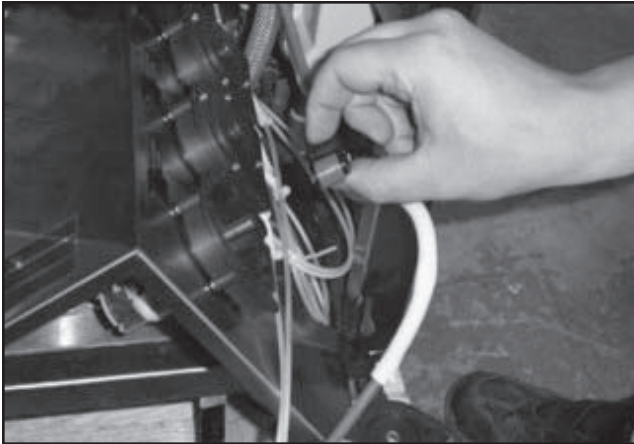

Removing the roller.

14. Place the roller and the rubber tube back in the pump casing. Place the pump cover back on and tighten-down with the four screws you previously removed.

15. Reattach the power wire and the wire for the priming switch.

16. Put the cover back on the control box and secure with the two screws previously removed.

17. Ensuring that all non-essential personnel are clear of the area, restore power to the unit. Turn the unit on and by using the priming switch, verify that the feeder pump operates and pumps fluid.

18. Replace the front door.

#### **AFTER MAINTENANCE ACTIONS**

None.

#### **SPECIAL NOTES**

Work performed on Jackson dishmachines by unauthorized or unqualified personnel may void the warranty. Before beginning this or any other maintenance evolution on a unit under warranty, you should contact a certified Jackson technician or Jackson Technical Service.

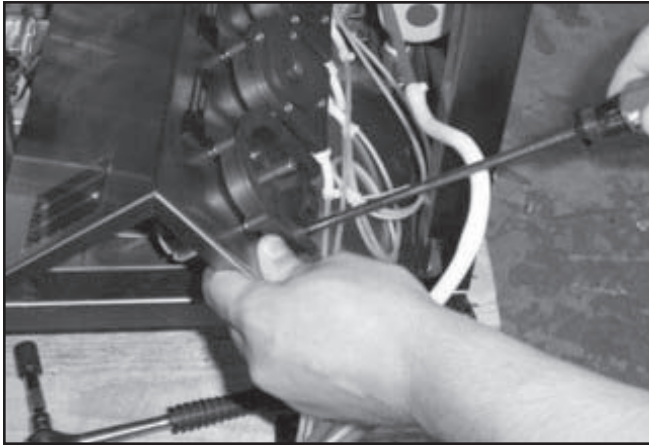

Removing the motor mounting screws.

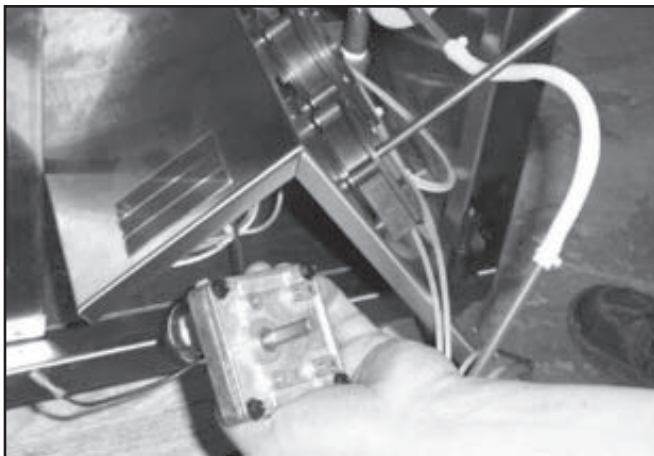

Removing the motor.

## SECTION 5: SERVICE PROCEDURES

### WASH TANK HEATER REPLACEMENT

Jackson glasswasher machines come equipped with heaters to ensure proper ware washing results. Occasionally, some of these components may need replacing to maintain optimum performance.

Jackson offers all of the repair parts necessary for performing this task.

The instructions provided here are for maintenance personnel only. Unauthorized persons should not attempt any of the steps contained in these instructions.



**CAUTION:** many of the instructions and steps within this document require the use of tools. Only authorized personnel should ever perform any maintenance procedure on the dish-machine!

#### PREPARATION

1. Power must be secured to the unit at the service breaker. Tag or lock-out the service breaker to prevent accidental or unauthorized energizing of the machine.

2. Ensure that incoming water to the machine is secured either by use of a shut-off valve or disconnecting the incoming water line.

3. The unit must be drained completely with the drain stopper removed.

#### TOOLS REQUIRED

The following tools will be needed to perform this maintenance evolution:

- 3/8" Nutdriver
- Ratchet
- 1/2" Socket/Wrench
- 3/8" Socket/Wrench
- Torque Wrench
- Amp Meter
- Phillipshead Screwdriver

#### TIME REQUIRED

It is estimated that it will take (1) person thirty minutes to perform this task, not including all of the items indicated in the section entitled "PREPARATION."

#### IMPORTANT NOTES

1. Read these instructions thoroughly before attempting this maintenance task. Become familiar with the parts and what actions need to be taken. This will save time in the long run!

#### STEPS

1. Remove the front door.

2. Remove the heater box cover with the 3/8" nutdriver. Set the cover and hardware to the side.

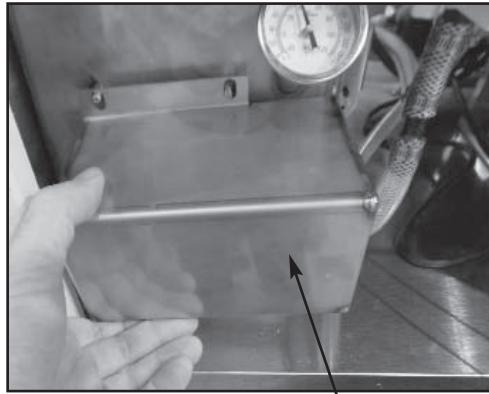

Removing the heater cover.

3. Remove the lower strainer.

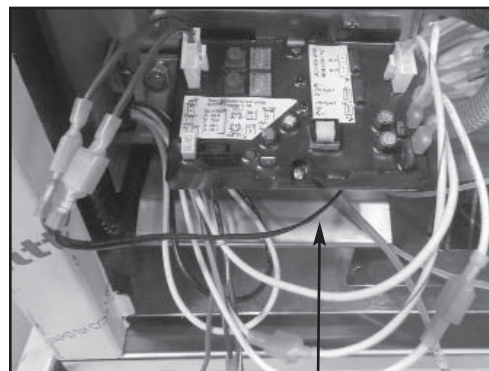

Remove the lower strainer.

4. Remove the ELAN thermostat using a phillipshead screw-driver. Either unplug the wires or cut the wire-tie and let the thermostat hang down out of the way.



Removing the ELAN thermostat.



---

## SECTION 5: SERVICE PROCEDURES

### WASH TANK HEATER REPLACEMENT (CONTINUED)

---

5. Remove the thermostat bracket with the 3/8" nutdriver.

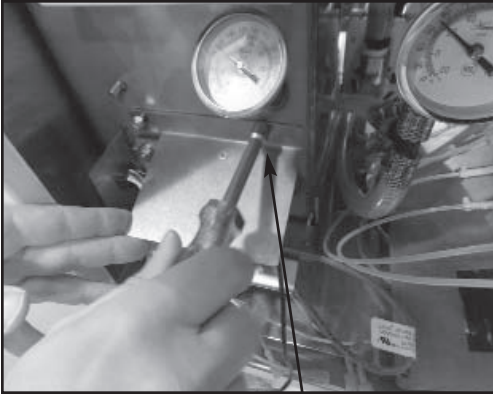

Removing the thermostat bracket.

8. Using a 1/2" socket or wrench, remove the heater mounting nuts.

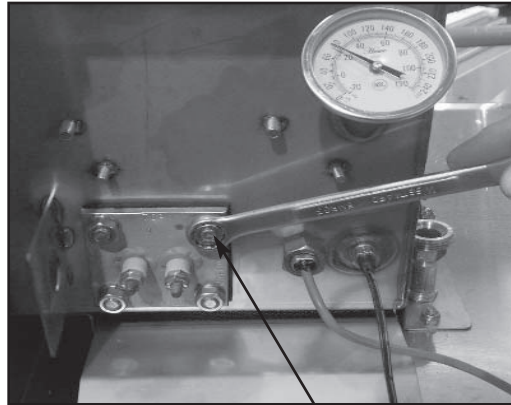

Removing the heater mounting nuts.

6. Remove the upper (wash) strainer. Set both strainers to the side where they will not be damaged or present a trip hazard.

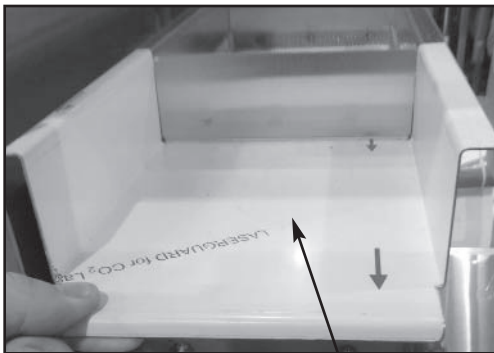

Removing upper (wash) strainer.

9. Removing the heater may require that you reach into the wash tank, grasp it, and give it a push out of the wash tank.

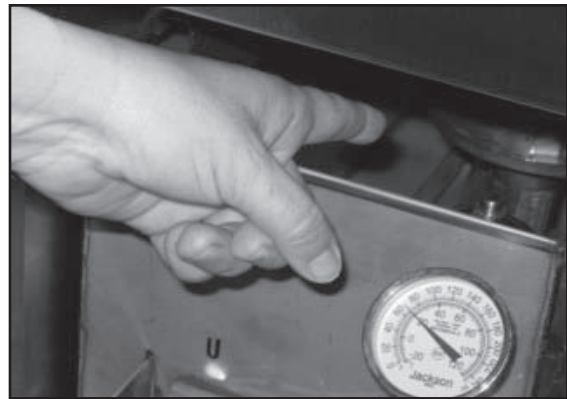

Reaching into the wash tank.

7. Using the 3/8" nutdriver, remove the nuts securing the heater wires to the heater. Then carefully pull the wires out of the way.

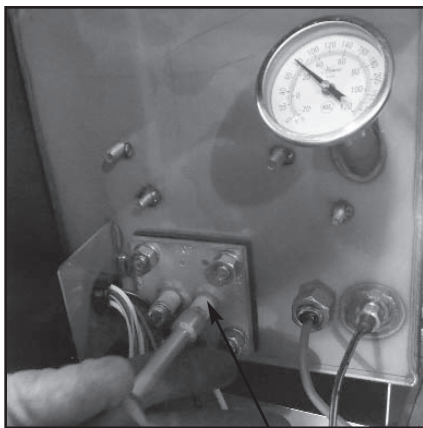

Removing the heater nuts.

10. Once the heater is pushed away from the tank wall, pull it out with your hands.

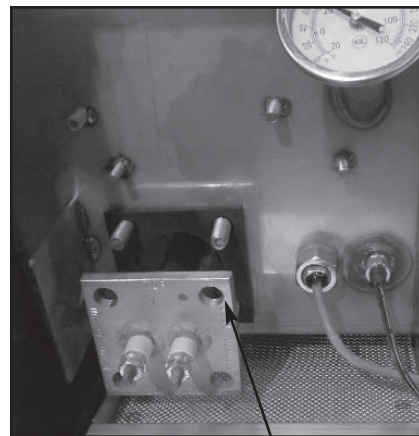

Pulling the heater out.

---

## SECTION 5: SERVICE PROCEDURES

### WASH TANK HEATER REPLACEMENT (CONTINUED)

---

11. Remove the old heater gasket and throw away.

12. Apply the new heater gasket.

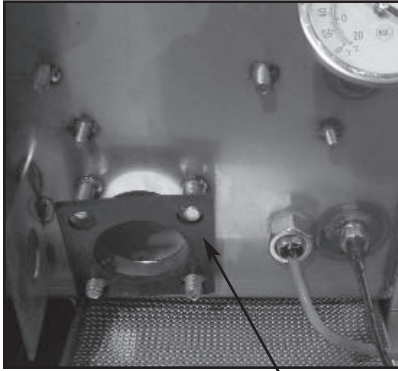

Applying the new heater gasket.

13. Take the new heater and slide it through the hole in the wash tank and line it up so the wash tank studs fit in the holes on the heater flange (Step 10 in reverse).

14. Place the mounting nuts and lockwashers on the studs and secure them with a 1/2" socket or wrench (Step 8 in reverse).

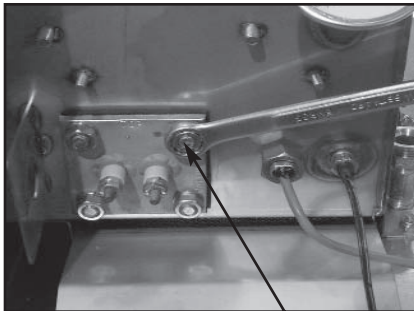

Securing the heater mounting nuts.

15. Place the heater wires on the heater and tighten the nuts down using the 3/8" nutdriver (Step 7 in reverse).

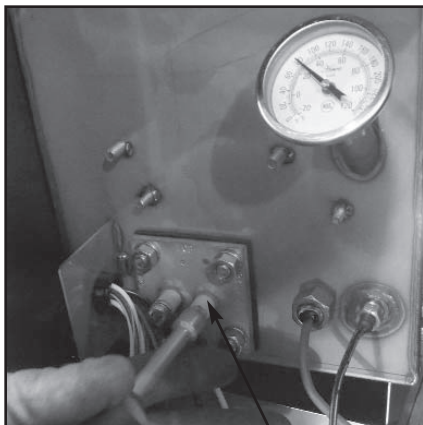

Replacing the heater nuts.

16. Using the torque wrench or a torque nutdriver (if available) torque the nuts holding the wires, jumpers and bus bars to 16 in-lbs.

17. Replace the thermostat bracket using the 3/8" nutdriver (Step 5 in reverse).

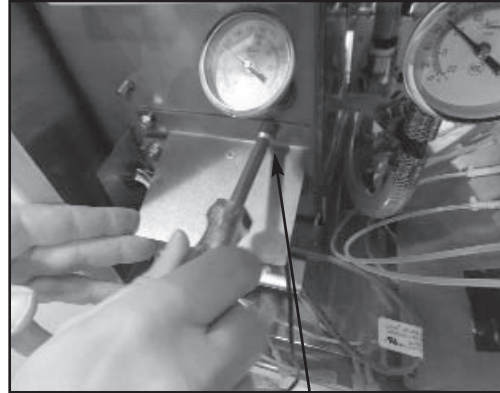

Replacing the thermostat bracket.

18. Replace the ELAN thermostat using a phillipshead screwdriver (Step 4 in reverse). If you unplugged the wires, reconnect them per the machine schematic on the back of the door. If not, move to the next step.



Replacing the ELAN thermostat.

19. Replace the upper and lower strainers.

20. Ensuring that all non-essential personnel are clear of the area, place the drain stopper back in the wash tank and restore power and water to the unit. Turn the unit on and allow it to fill normally.

21. Verify that there are no leaks around the heater. If there are, attempt to tighten it down (with power secured to the unit at the service breaker to prevent injury) as the tank will change shape slightly as it heats up.

22. Use the amp meter to take readings off of the power lines to the heater, verifying the amperage draw to the machine data plate.

---

## SECTION 5: SERVICE PROCEDURES

### WASH TANK HEATER REPLACEMENT (CONTINUED)

23. Wait until the heater contactor kicks out (meaning that the tub has reached the appropriate temperature) and allow the machine to operate approximately ten minutes to verify that there are no leaks and that the heater is maintaining the tank temperature.

24. Replace the heater cover (Step 2 in reverse).

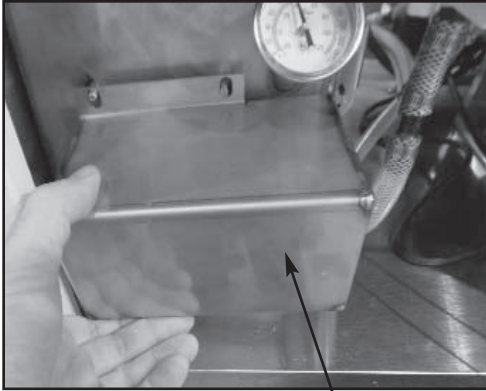

Replacing the heater cover.

25. Replace the front door.

#### **AFTER MAINTENANCE ACTIONS**

Service personnel may want to drain the machine and allow it to cool down. Secure power to the unit at the service breaker and then verify the torque of all fasteners covered in this instruction.

#### **SPECIAL NOTES**

Work performed on Jackson dishmachines by unauthorized or unqualified personnel may void the warranty. Before beginning this or any other maintenance evolution on a unit under warranty, you should contact a certified Jackson technician or Jackson Technical Service.

## SECTION 5: SERVICE PROCEDURES

### THERMOSTAT REPLACEMENT

Jackson glasswasher machines come equipped with thermostats to ensure proper ware washing results. Occasionally, some of these components may need replacing to maintain optimum performance.

Jackson offers all of the repair parts necessary for performing this task.

The instructions provided here are for maintenance personnel only. Unauthorized persons should not attempt any of the steps contained in these instructions.



**CAUTION:** many of the instructions and steps within this document require the use of tools. Only authorized personnel should ever perform any maintenance procedure on the dish-machine!

#### PREPARATION

1. Power must be secured to the unit at the service breaker. Tag or lock out the service breaker to prevent accidental or unauthorized energizing of the machine.
2. Ensure that incoming water to the machine is secured either by use of a shut-off valve or disconnecting the incoming water line.
3. The unit must be drained completely with the drain stopper removed.

#### TOOLS REQUIRED

The following tools will be needed to perform this maintenance evolution:

- 3/8" Nutdriver
- 7/16" Nutdriver
- 7/16" Wrench
- Needle-nose Pliers
- Phillipshead Screwdriver

#### TIME REQUIRED

It is estimated that it will take (1) person twenty minutes to perform this task, not including all of the items indicated in the section entitled "PREPARATION."

#### IMPORTANT NOTES

1. Read these instructions thoroughly before attempting this maintenance task. Become familiar with the parts and what actions need to be taken. This will save time in the long run!

#### STEPS

1. Remove the front door.
2. Remove the heater box cover with the 3/8" nutdriver. Set the cover and hardware to the side.

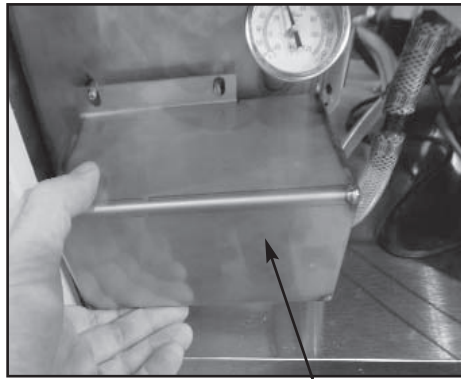

Removing the heater cover.

3. Using the pair of needle-nose pliers (if necessary), disconnect the terminals from the thermostat probe. Be careful not to damage the terminals or the wires or they will have to be replaced.

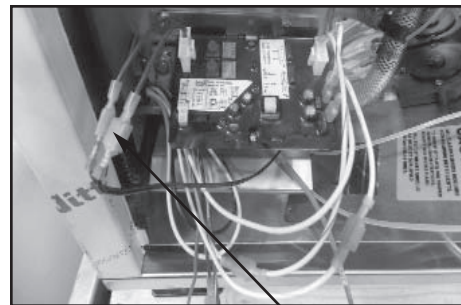

Disconnect the probe terminals.

4. Unplug all of the terminals/wires connected to the ELAN thermostat.

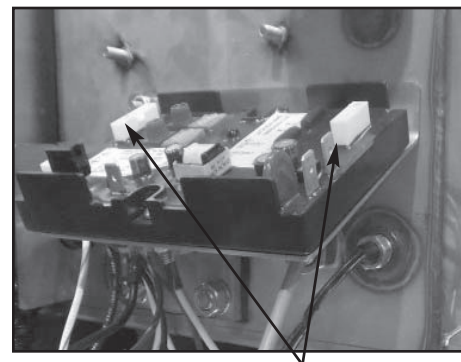

Unplug all of the terminals/wires.

## SECTION 5: SERVICE PROCEDURES

### THERMOSTAT REPLACEMENT (CONTINUED)

5. Remove the ELAN thermostat using a phillipshead screwdriver.

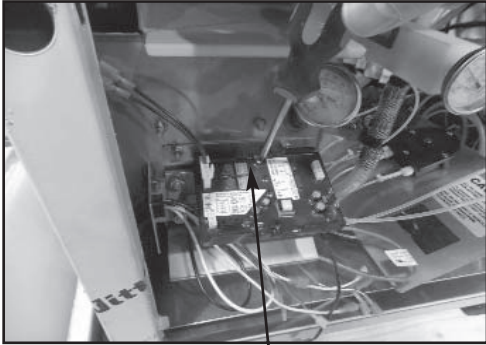

Removing the ELAN thermostat.

6. Remove the thermostat bracket with the 3/8" nutdriver.

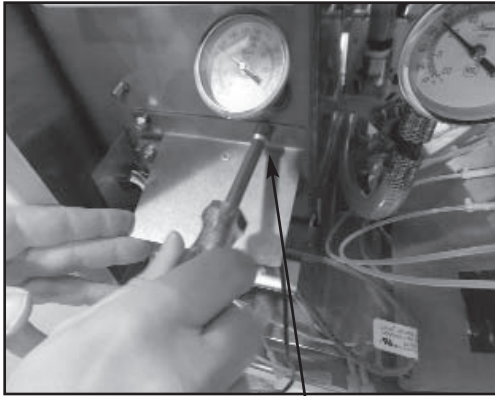

Removing the thermostat bracket.

7. Use the 7/16" wrench to loosen and remove the imperial brass fitting.

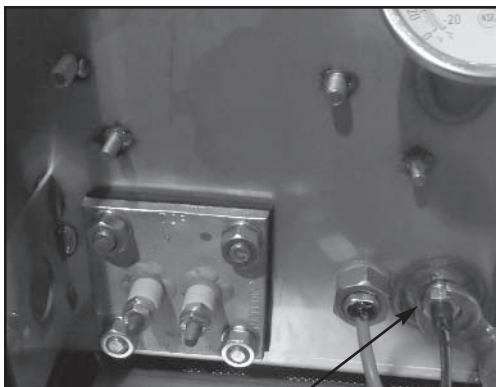

Removing the imperial brass fitting.

8. Pull the thermostat probe out of the wash tank.

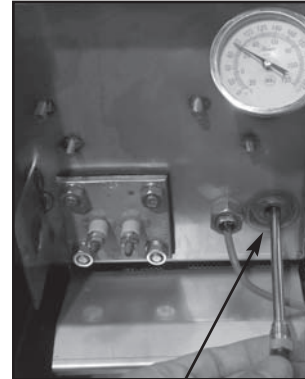

Pulling the thermostat probe out.

9. Place the new thermostat probe in the new imperial brass fitting provided in your kit. Use the 7/16" wrench to tighten it down after getting the fitting hand-tight in the tank.

10. Replace the thermostat bracket with the 3/8" nutdriver (Step 6 in reverse).

11. Place the new ELAN thermostat on the bracket and secure it with the phillipshead screwdriver.

12. Reconnect the wires per the machine schematic on the back of the door.

13. Place the drain stopper back in the wash tank. Restore power and water to the unit. Then allow the unit to operate normally.

14. Verify that the thermostat operates the heater contactor. Once you have determined the heater contactor is working, adjust the wash tank thermostat to ensure that the temperature is maintained in accordance with the specifications on the machine data plate.

15. Replace the heater cover.

16. Replace the front door.

#### **AFTER MAINTENANCE ACTIONS**

None.

#### **SPECIAL NOTES**

Work performed on Jackson dishmachines by unauthorized or unqualified personnel may void the warranty. Before beginning this or any other maintenance evolution on a unit under warranty, you should contact a certified Jackson technician or Jackson Technical Service.

---

## SECTION 5: SERVICE PROCEDURES

### WASH MOTOR REPLACEMENT

Jackson glasswasher machines come equipped with wash pumps that have powerful motors attached to them to ensure proper ware washing results. Occasionally, these assemblies may require replacing to maintain optimum performance. Jackson offers all of the repair parts necessary for performing this task.

The instructions provided here are for maintenance personnel only. Unauthorized persons should not attempt any of the steps contained in these instructions.



**CAUTION:** many of the instructions and steps within this document require the use of tools. Only authorized personnel should ever perform any maintenance procedure on the dish-machine!

#### PREPARATION

1. Power must be secured to the unit at the service breaker. Tag or lock out the service breaker to prevent accidental or unauthorized energizing of the machine.
2. Ensure that incoming water to the machine is secured either by use of a shut-off valve or disconnecting the incoming water line.
3. The unit must be drained completely with the drain stopper removed.

#### TOOLS REQUIRED

The following tools will be needed to perform this maintenance evolution:

- 1/4" Nutdriver
- 5/16" Nutdriver
- Needle-nose Pliers
- 7/16" Combination Wrench
- (2) 9/16" Combination Wrench

#### TIME REQUIRED

It is estimated that it will take (1) person ninety minutes per motor to perform this task, not including all of the items indicated in the section entitled "PREPARATION."

#### IMPORTANT NOTES

1. Read these instructions thoroughly before attempting this maintenance task. Become familiar with the parts and what actions need to be taken. This will save time in the long run!

#### STEPS

1. To access the assembly, you need to get access to the rear of the unit. This may require that water, drain, and power lines be disconnected so that the unit can be moved for access.

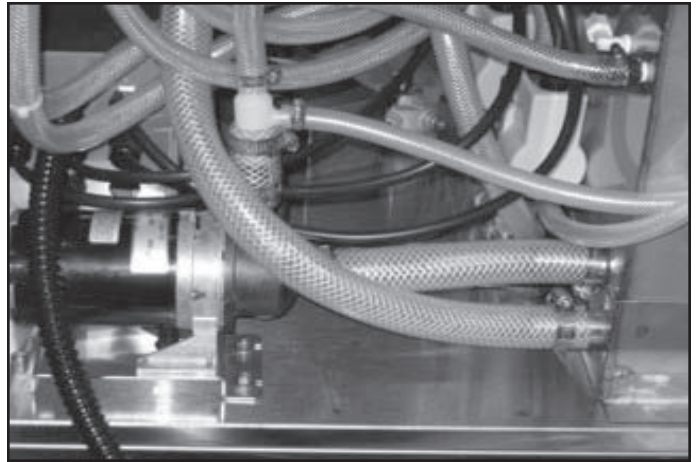

Gain access to the rear of the machine.

2. Using the 5/16" nutdriver, loosen the clamps on the suction hose.

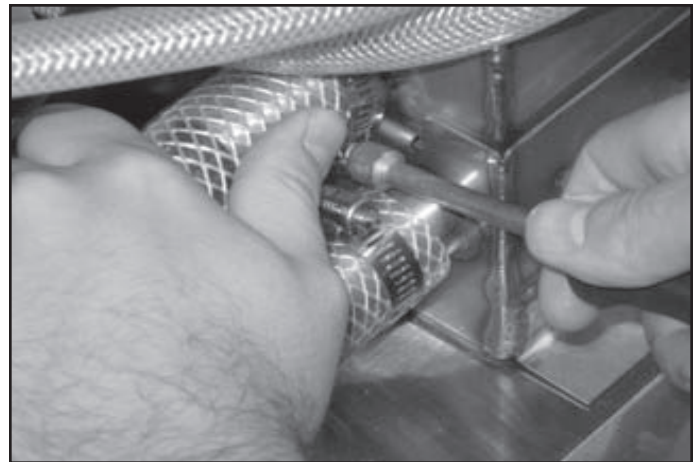

Loosening the suction hose clamps.

3. Using the same nutdriver, loosen the discharge hose where it connects to the tub weldment.
4. Pull the discharge hose out and away from the tub.
5. Remove the motor assembly mounting nuts using the 7/16" combination wrench.
6. With the nuts removed, grasp the motor assembly and lift up on it to clear the mounting studs.

---

## SECTION 5: SERVICE PROCEDURES

### WASH MOTOR REPLACEMENT (CONTINUED)

---

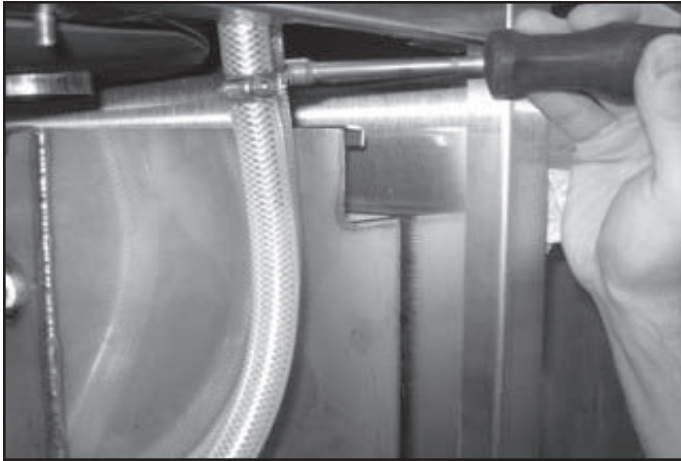

Loosening the discharge hose clamp.

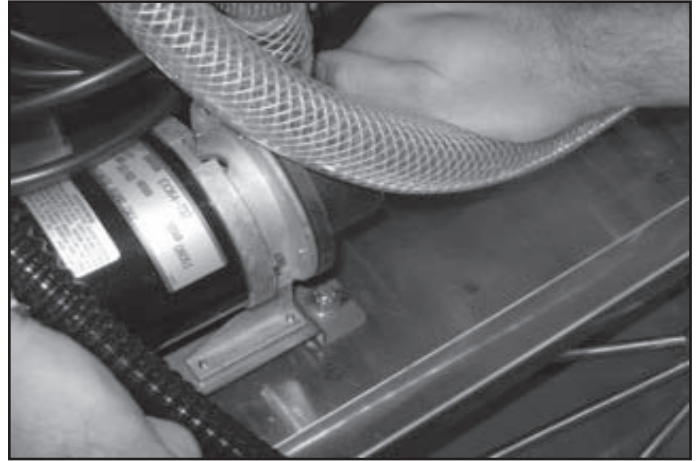

Lifting up on the motor.

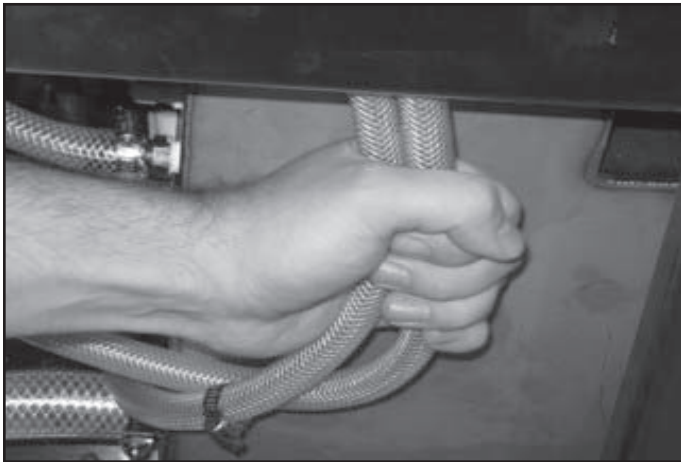

Pulling the discharge hose out.

7. Turn the motor so that you will have access to the wiring cover on the back. Be careful not to pull or yank too hard as the motor is still connected to the unit by way of the power lines.



Suction hose coming off when moving the assembly.

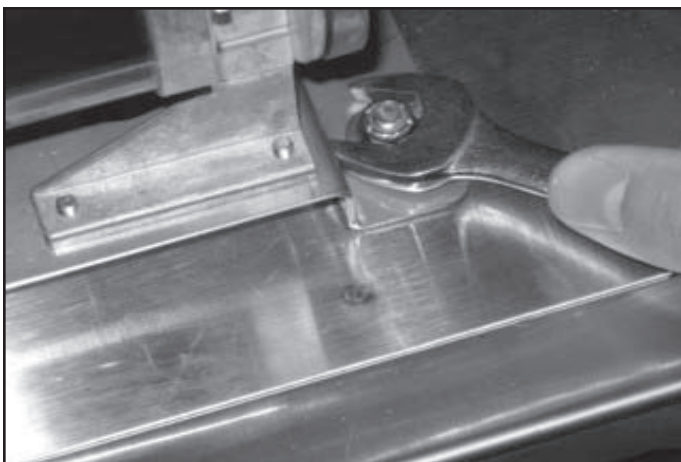

Removing the assembly mounting nuts.

8. Take the needle-nose pliers and remove the power wires from the terminals within the motor.

9. The motor should now be free. Replace with a new motor by performing the removal steps in reverse.

10. Place the discharge hose assembly back on the discharge of the pump and tighten-down.

11. Lift the assembly into place within the unit, ensuring that the suction hose is attached and lines up. Move the assembly so the mounting bracket slides over the mounting studs. Position the assembly so that the suction hose is not kinked.

21. Replace and tighten-down the nuts securing the bracket to the frame.

---

## SECTION 5: SERVICE PROCEDURES

### WASH MOTOR REPLACEMENT (CONTINUED)

22. Tighten the clamps for the suction hose.
23. Connect the discharge hose to the tub and tighten-down the hose clamp.

#### **AFTER MAINTENANCE ACTIONS**

Verify the operation of the new wash motor and pump assembly by running the unit for approximately 15 minutes. Check for leaks and correct as necessary.

#### **SPECIAL NOTES**

Work performed on Jackson dishmachines by unauthorized or unqualified personnel may void the warranty. Before beginning this or any other maintenance evolution on a unit under warranty, you should contact a certified Jackson technician or Jackson Technical Service.



---

## **SECTION 6: PARTS SECTION**

**SECTION 6: PARTS SECTION**  
**CONTROL BOX ASSEMBLY - DELTA 115**

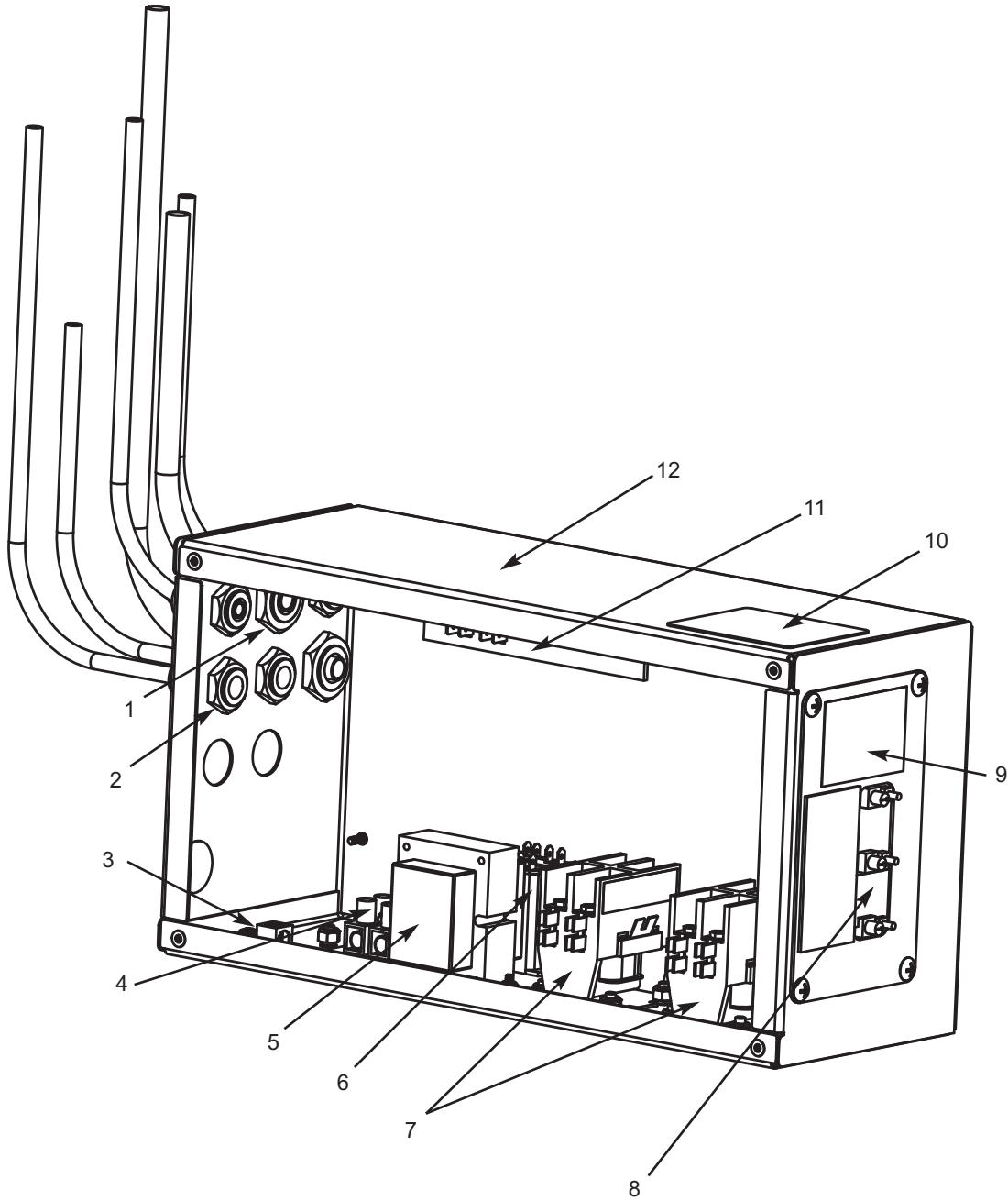

---

**SECTION 6: PARTS SECTION**  
**CONTROL BOX ASSEMBLY - DELTA 115**

---

<b>Number</b>	<b>QTY</b>	<b>Part Number</b>	<b>Description</b>
1	4	05975-011-49-03	Fitting
2	2	05975-011-65-51	Fitting
3	1	05940-200-76-00	Ground Lug
4	1	05700-011-40-05	Separator
5	1	05950-002-16-78	Transformer
6	1	05945-111-35-19	Relay
7	2	05945-109-05-69	Contactactor
8	1	05700-003-55-38	Access Panel
9	1	09905-004-09-40	Decal, Warning, Disconnect Power
10	1	09905-011-68-99	Decal, Caution
11	1	05940-002-78-97	Terminal Board
12	1	05700-004-27-24	Complete Assembly

**SECTION 6: PARTS SECTION**  
**CONTROL BOX ASSEMBLY - DELTA 1200**

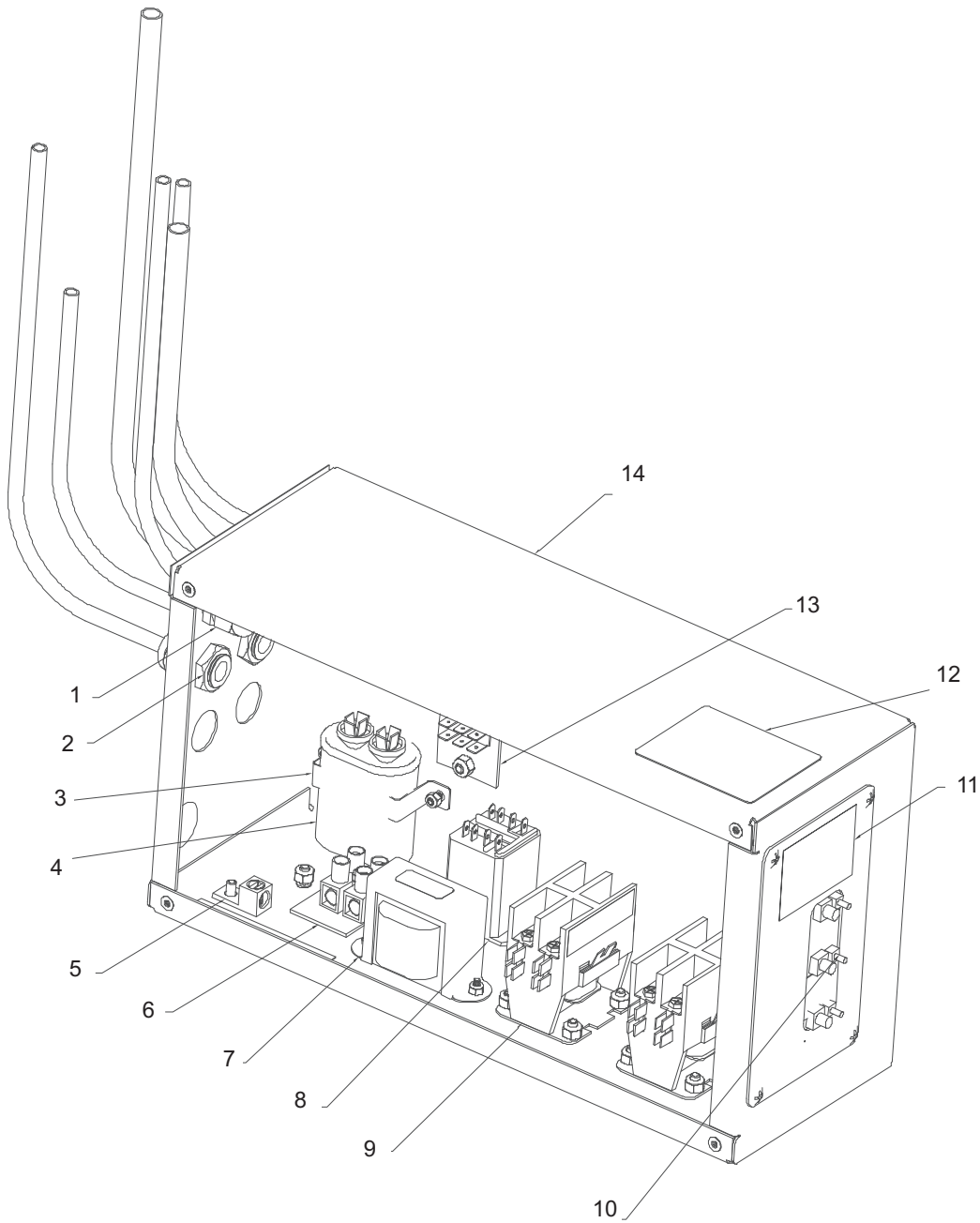

---

**SECTION 6: PARTS SECTION**  
**CONTROL BOX ASSEMBLY - DELTA 1200**

---

Number	QTY	Part Number	Description
1	2	05975-011-49-03	Fitting
2	3	05975-011-65-51	Fitting
3	1	05700-003-56-00	Bracket
4	1	05910-003-43-01	Capacitor
5	1	05940-200-76-00	Ground Lug
6	1	05700-011-40-05	Separator
7	1	05950-011-61-67	Transformer
8	1	05945-111-47-51	Relay
9	2	05945-002-74-20	Contactactor
10	1	05700-003-55-38	Access Panel
11	1	09905-100-75-93	Decal, Warning, Disconnect Power
12	1	09905-011-68-99	Decal, Caution
13	1	05940-002-78-97	Terminal Board
14	1	05700-003-55-37	Complete Assembly

**SECTION 6: PARTS SECTION**  
**OUTER SHELL ASSEMBLY - DELTA 115 AND DELTA 1200**

**OUTER SHELL**

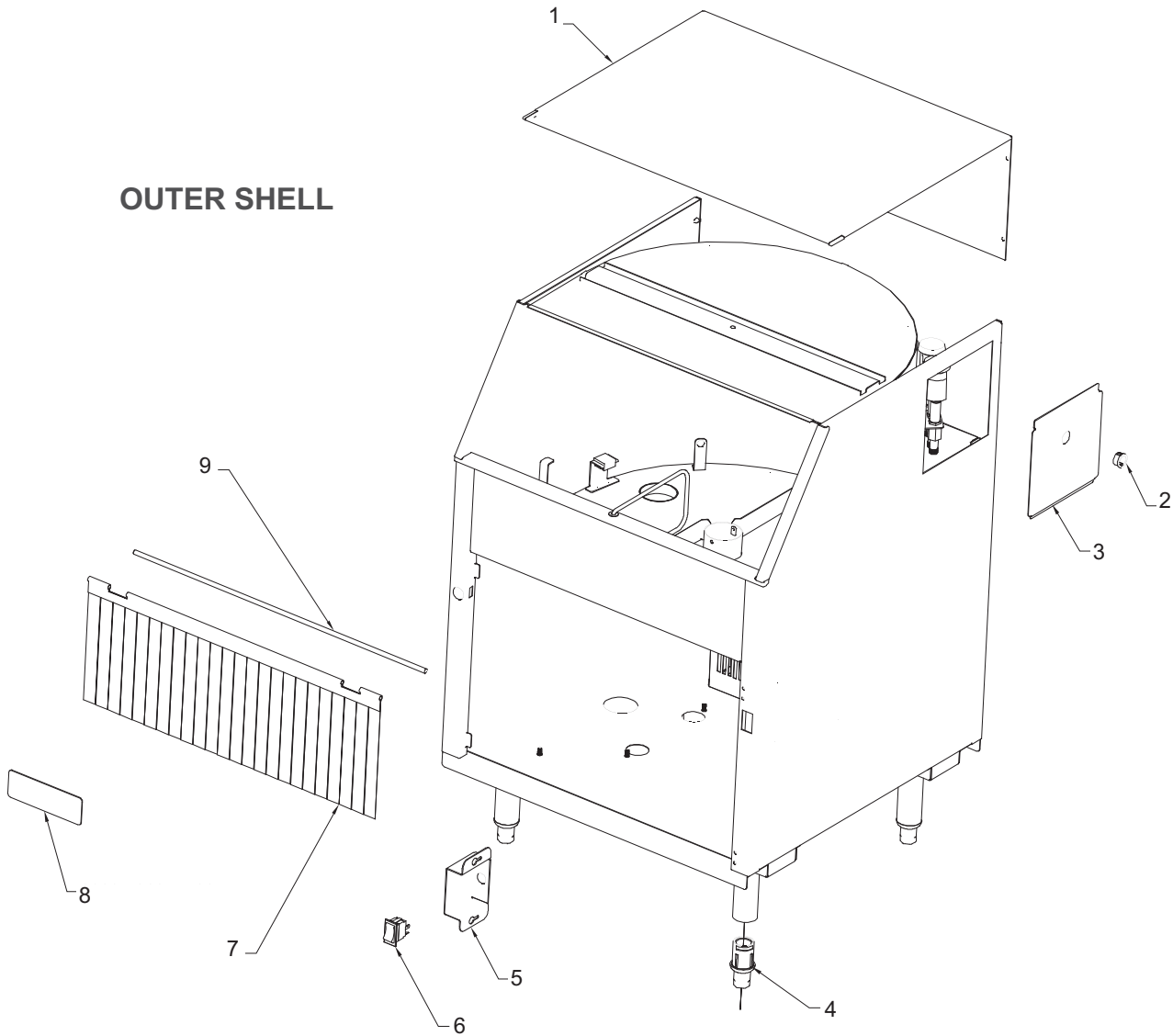

---

## SECTION 6: PARTS SECTION

### OUTER SHELL ASSEMBLY - DELTA 115 AND DELTA 1200

Number	QTY	Part Number	Description
1	1	05700-003-57-95	Outer Cover
2	1	05975-210-03-00	Grommett
3	1	05700-003-58-73	Access Cover
4	4	05340-108-01-03	Bullet Foot
5	1	05700-003-60-39	Switch Cover
6	1	05930-011-61-69	Power Switch
7	1	08415-003-60-35	Curtain
8	1	09905-003-57-30	Jackson Decal
9	1	05700-003-60-38	Curtain Rod

**SECTION 6: PARTS SECTION**  
**CHEMICAL FEEDER PUMP ASSEMBLY - DELTA 115 AND DELTA 1200**

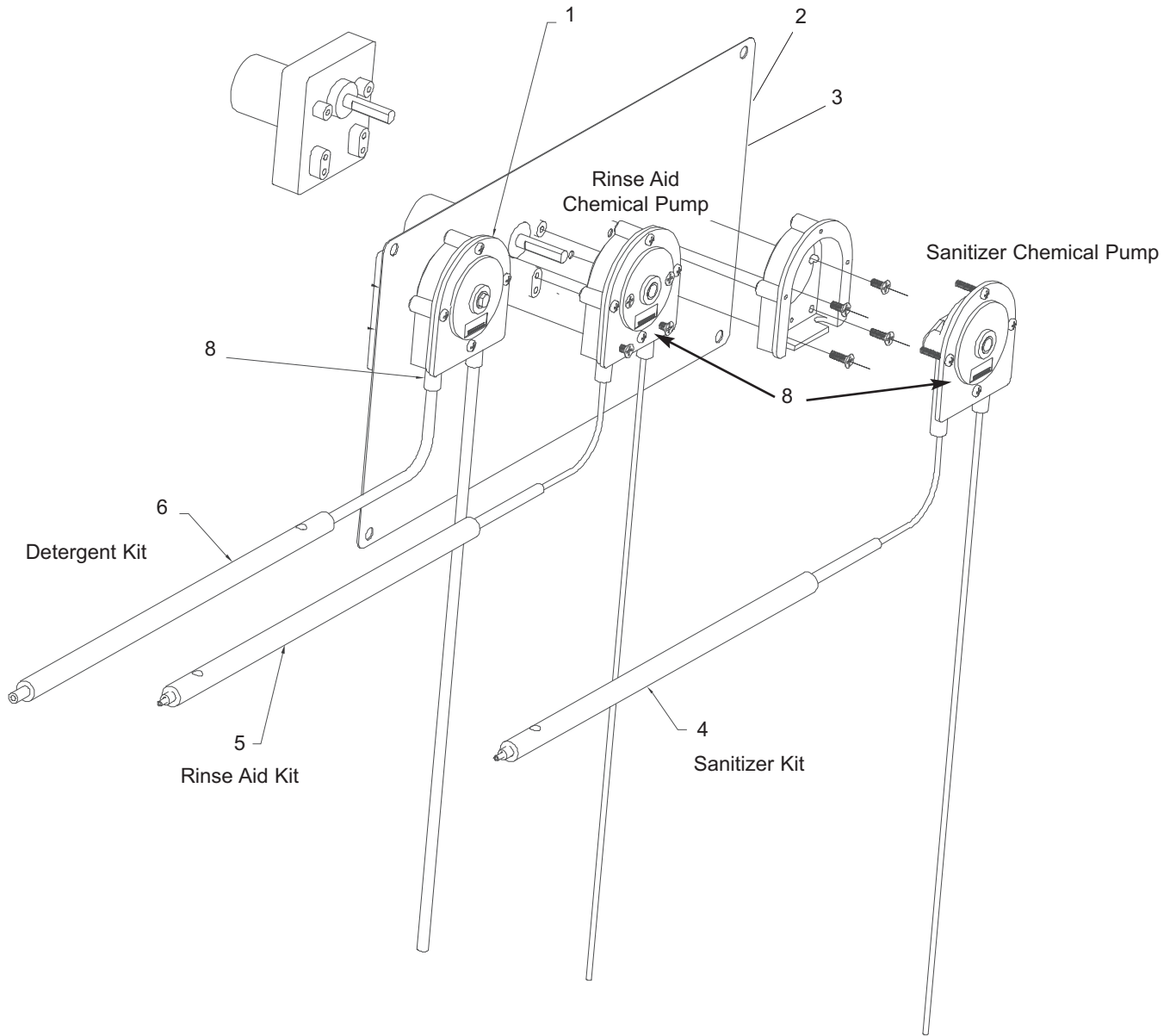



---

## SECTION 6: PARTS SECTION

### CHEMICAL FEEDER PUMP ASSEMBLY - DELTA 115 AND DELTA 1200

Number	QTY	Part Number	Description
1	1	05700-003-87-08	14 RPM Peri-Pump
2	1	05700-003-55-29	Cover and Peri-Pump Assembly
3	1	05700-003-55-34	Cover only
4	1	06401-003-61-21	Sanitizer Tube Replacement Kit
5	1	06401-003-61-22	Rinse Aid Tube Replacement Kit
6	1	06401-003-61-23	Detergent Tube Replacement Kit
7	2	05700-011-65-21	Rinse Aid & Sanitizer Squeeze Tubes
8	1	05700-003-22-89	Detergent Squeeze Tube

**SECTION 6: PARTS SECTION**  
**RINSE ASSEMBLY - DELTA 115 AND DELTA 1200**

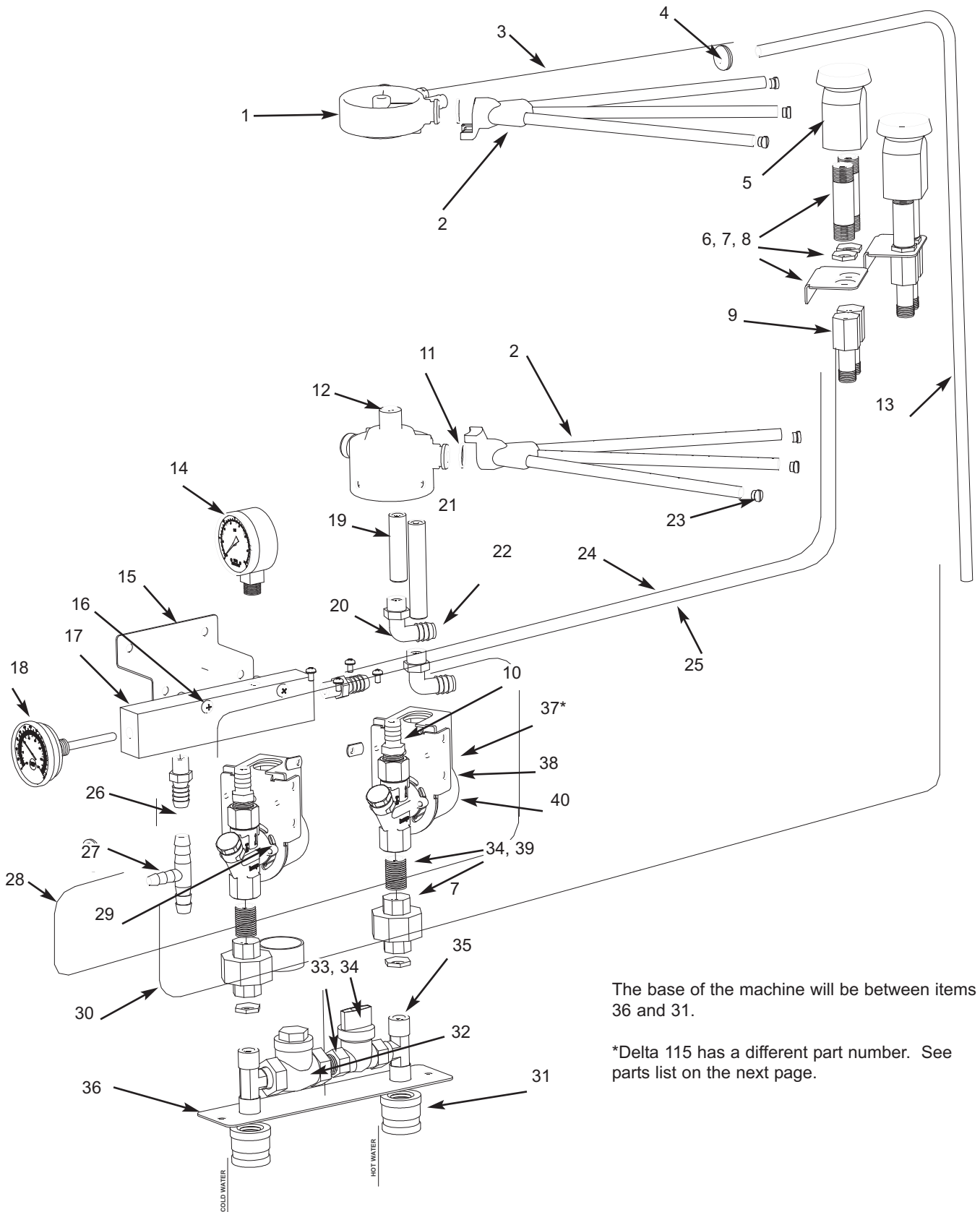

The base of the machine will be between items 36 and 31.

\*Delta 115 has a different part number. See parts list on the next page.

**SECTION 6: PARTS SECTION**  
**RINSE ASSEMBLY - DELTA 115 AND DELTA 1200**

Number	QTY	Part Number	Description
1	1	09330-003-45-71	Upper Rinse Casting
2	2	05700-003-56-57	Rinse Arm
3	1	05700-003-45-71	Hose
4	1	05330-003-41-73	Grommet
5	2	05700-003-55-31	Vacuum Breaker
6	4	04730-011-61-57	Vacuum Breaker Nipple
7	6	05310-011-61-45	Hex Nut
8	2	05700-003-58-03	Vacuum Breaker Mounting Bracket
9	4	04730-011-61-47	Vacuum Breaker Fitting
10	2	04730-002-18-54	Fitting
11	2	05330-011-74-55	O-Ring
12	1	09330-003-45-67	Lower Wash Casting
13	1	05700-003-49-32	Tube
14	1	06885-011-64-29	Pressure Gauge
15	1	05700-003-58-79	Manifold Mounting Bracket
16	2	05305-011-66-03	10-32 Screw
17	1	05700-031-60-37	Manifold Block
18	1	06685-111-35-30	Thermometer
19	1	05700-003-60-45	Tube
20	2	04730-003-07-07	Elbow
21	1	04710-003-60-46	Tube
22	2	04730-003-60-47	Fitting
23	6	05700-003-55-57	End Cap
24	1	05700-003-49-23	Hose, 1/2" ID x 36" Long, Polybraid
25	1	05700-003-49-18	Hose, 1/2" ID x 45" Long, Polybraid
26	1	05700-003-49-23	Fitting
27	1	09330-003-51-19	T-Fitting
28	1	05700-003-57-29	Tubing, 1/2" ID x 28" Long
29	1	09905-011-65-47	Decal, Blue
30	1	05700-003-49-28	Hose, 3/8" x 13" Long, Polybraid
31	2	04730-011-61-52	Coupling
32	1	04820-011-61-56	Check Valve
33	1	04820-011-61-58	Ball Valve
34	3	04730-002-18-00	Close Nipple
35	2	04730-011-61-53	Tee
36	1	05700-003-60-21	Mounting Plate
37	2	04730-011-61-54	S-45 Valve (Delta 1200)
37*	2	04730-002-75-48	S-45 Valve (Delta 115)
38	2	05975-111-62-70	S-45 Valve Cover
39	2	04730-003-60-57	Union
40	1	09905-011-65-46	Decal, Red

**SECTION 6: PARTS SECTION**  
**WASH SYSTEM - DELTA 115**

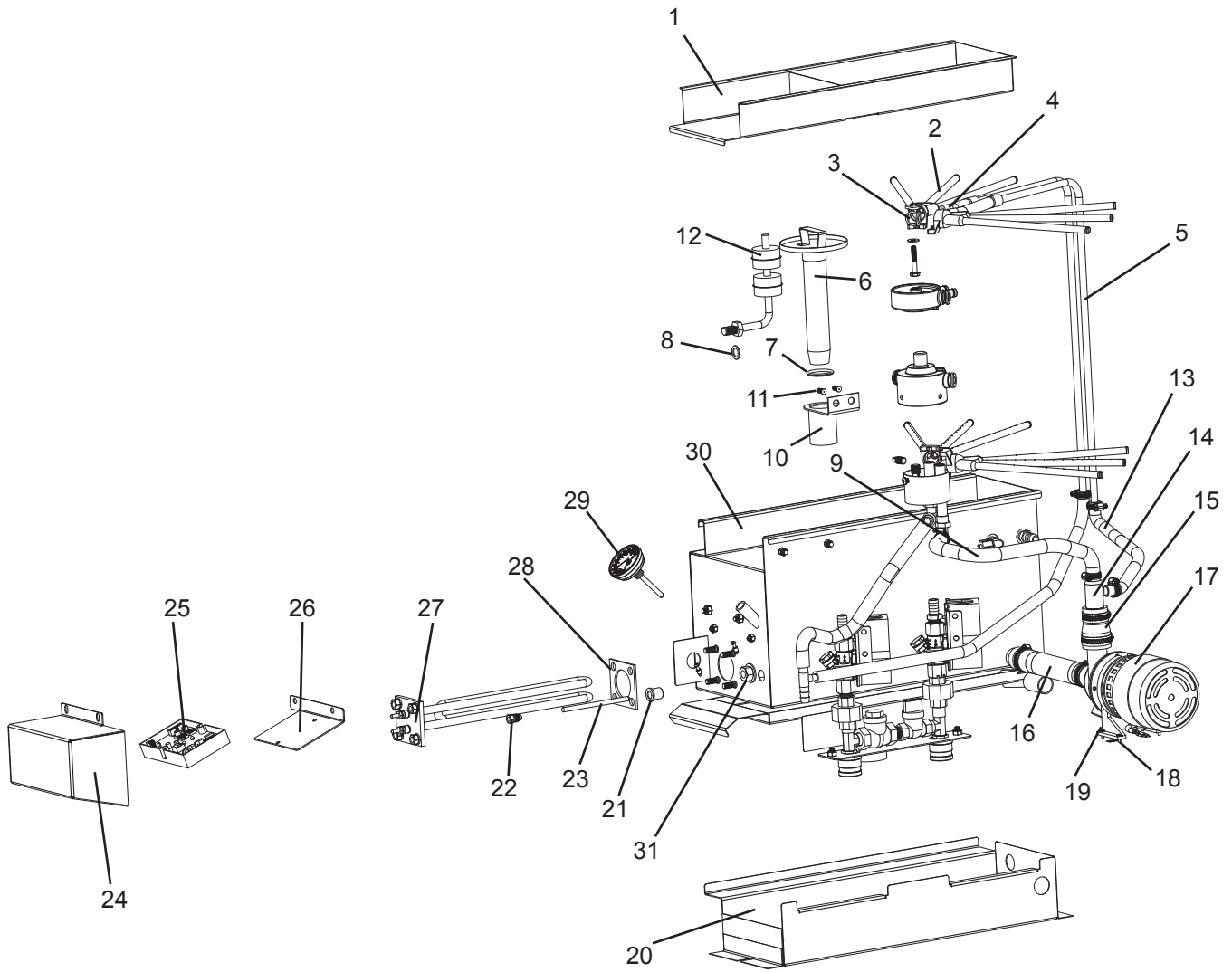

---

**SECTION 6: PARTS SECTION****WASH SYSTEM - DELTA 115**

---

Number	QTY	Part Number	Description
1	1	05700-021-61-78	Wash Tank Strainer
2	2	05700-003-42-83	Wash Arm
3	4	05330-011-74-55	O-Ring, 13/16" OD
4	1	05330-003-41-73	Grommett
5	1	05700-003-49-32	Tube, Stainless Steel
6	1	05700-021-62-22	Wash Tank Overflow
7	1	05330-400-05-00	Wash Tank O-Ring
8	1	05311-011-62-65	Washer
9	1	04720-003-57-29	Hose, 3/4" OD
10	1	05700-003-59-21	Overflow Support
11	2	05310-373-01-00	10-24 Locknut
12	1	06680-121-70-16	Float
13	1	05700-003-49-27	5" Long Hose
14	1	04730-003-40-64	Pump Hose Connector
15	1	05700-003-59-96	Pump Discharge Hose
16	1	05700-003-60-25	Pump Suction Hose
17	1	06105-003-44-22	Wash Pump
18	4	05305-002-46-43	6-32 x 1/4" Screw
19	1	09905-011-86-86	Ground Decal
20	1	05700-003-60-00	Drain Weldment
21	1	05700-011-71-93	Washier, 1/2" Flat
22	1	05310-924-02-05	Thermostat Probe Fitting
23	1	06685-004-17-26	Thermostat Probe
24	1	05700-004-28-55	Heater Cover
25	1	06685-004-17-27	Thermostat, ELAN Electronic Dual
26	1	05700-004-28-56	Thermostat Bracket
27	1	04540-004-25-61	Wash Heater
28	1	05330-011-61-34	Wash Heater Gasket
29	1	06685-111-35-30	Thermometer
30	1	05700-003-60-12	Wash Tank
31	1	05310-011-72-58	Hexnut, 1/2"-13 S/S

# SECTION 6: PARTS SECTION

## WASH SYSTEM - DELTA 1200

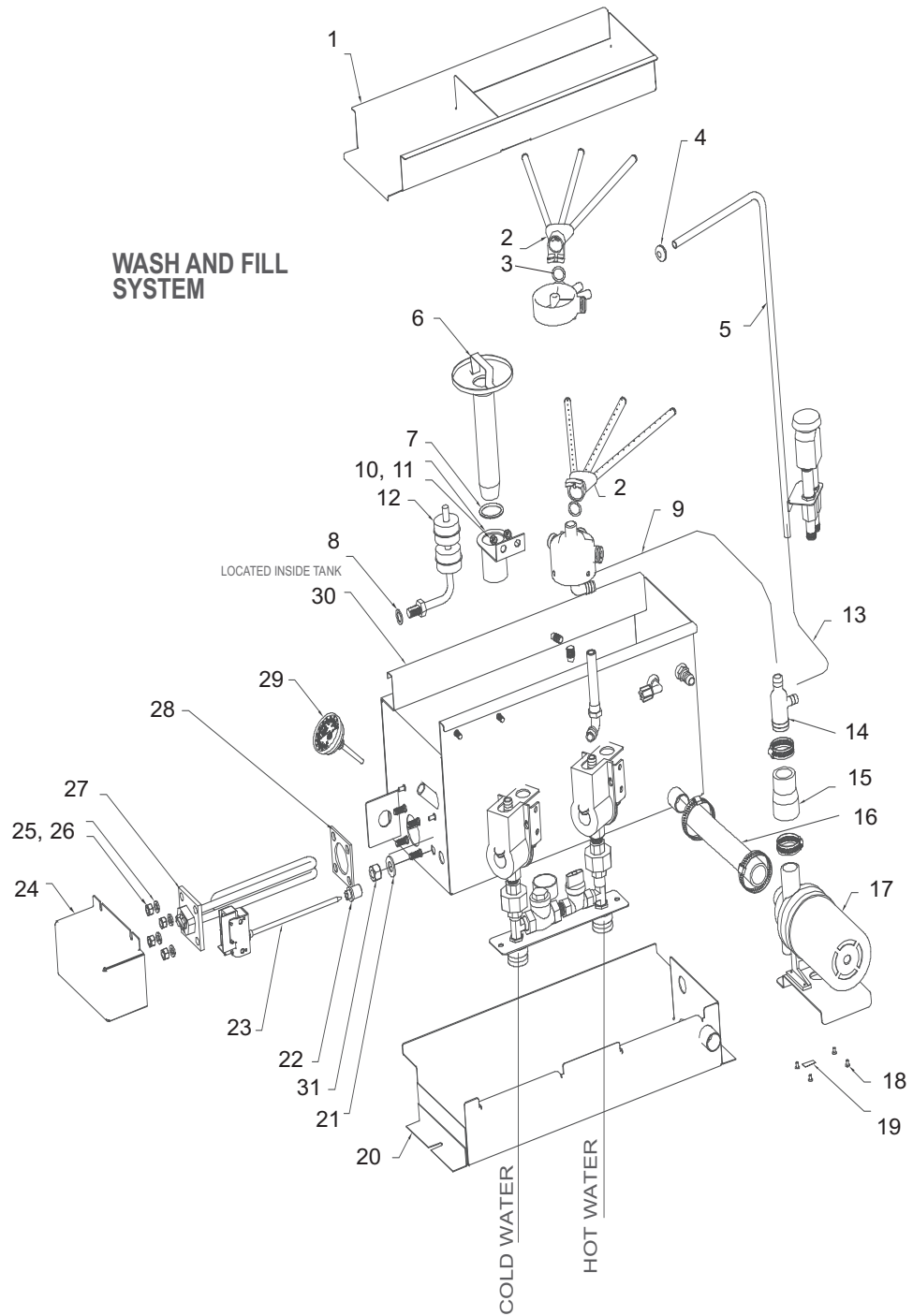

---

**SECTION 6: PARTS SECTION**

---

## WASH SYSTEM - DELTA 1200

Number	QTY	Part Number	Description
1	1	05700-021-61-78	Wash Tank Strainer
2	2	05700-003-42-83	Wash Arm
3	4	05330-011-74-55	O-Ring, 13/16" OD
4	1	05330-003-41-73	Grommet
5	1	05700-003-49-32	Tube, Stainless Steel
6	1	05700-021-62-22	Wash Tank Overflow
7	1	05330-400-05-00	Wash Tank O-Ring
8	1	05311-011-62-65	Washer
9	1	04720-003-57-29	Hose, 3/4" OD
10	1	05700-003-59-21	Overflow Support
11	2	05310-373-01-00	10-24 Locknut
12	1	06680-121-70-16	Float
13	1	05700-003-49-27	5" Long Hose
14	1	04730-003-40-64	Pump Hose Connector
15	1	05700-003-59-96	Pump Discharge Hose
16	1	05700-003-60-25	Pump Suction Hose
17	1	06105-003-44-22	Wash Pump
18	1	05305-002-46-43	6-32 x 1/4" Screw
19	1	09905-011-86-86	Ground Decal
20	1	05700-003-60-00	Drain Weldment
21	1	05700-011-71-93	Washer, 1/2" Flat
22	1	05310-924-02-05	Thermostat Fitting
23	1	05930-510-02-79	Thermostat
24	1	05700-003-60-24	Heater Cover
25	4	05311-275-01-00	Lockwasher
26	4	05310-275-01-00	Hex Nut
27	1	04540-021-61-66	Wash Heater
28	1	05330-011-61-34	Wash Heater Gasket
29	1	06685-111-35-30	Thermometer
30	1	05700-003-60-12	Wash Tank
31	1	05310-011-72-58	Hexnut, 1/2"-13 S/S

---

## SECTION 6: PARTS SECTION

### CONVEYOR AND DRIVE SYSTEM

---

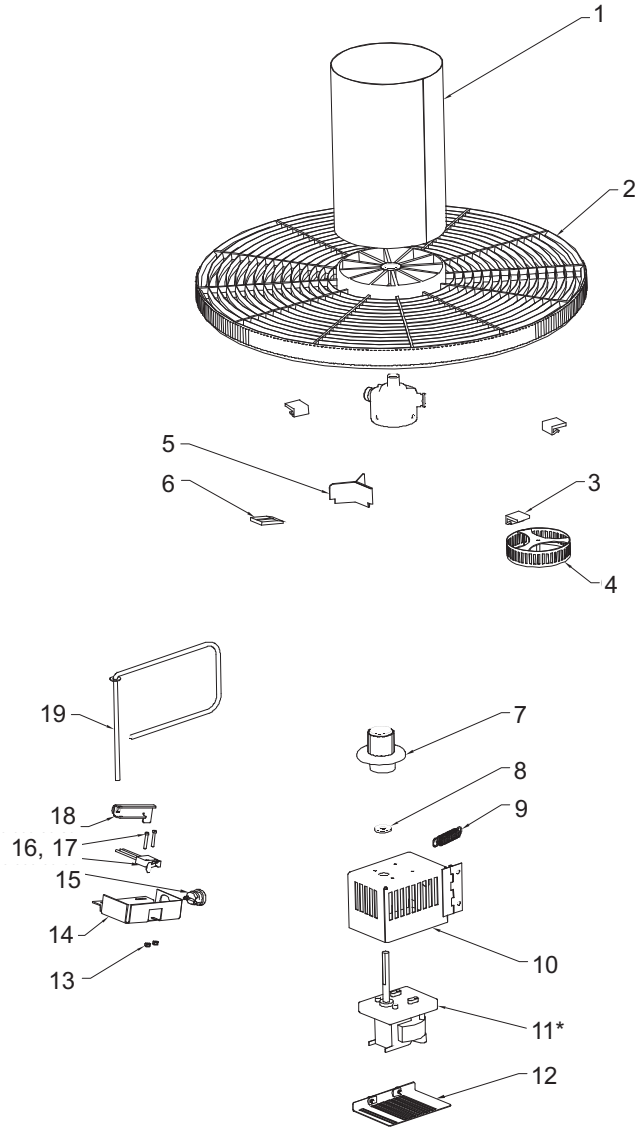

\*Delta 115 has a different part number. See parts list on the next page.



**SECTION 6: PARTS SECTION**  
**CONVEYOR AND DRIVE SYSTEM**

Number	QTY	Part Number	Description
1	1	05700-003-49-10	Cylinder
2	1	09330-003-45-66	Rack
3	3	09330-003-51-17	Guide Block
4	1	05700-003-59-93	Strainer Weldment
5	1	05700-003-48-99	Drain Defelctor, Wash
6	1	09330-003-58-52	Plate, Skid
7	1	09330-003-58-32	Drive Gear
8	1	05330-003-41-75	Washer
9	1	05340-003-41-83	Extension Spring
10	1	05700-003-48-87	Gear Motor Box
11	1	06105-003-44-23	Gear Motor (Delta 1200)
11*	1	06105-004-26-30	Gear Motor (Delta 115)
12	1	05700-003-48-57	Gear Motor Box Cover
13	2	05975-011-63-56	Strain Relief
14	1	05700-003-60-13	Switch mounting bracket
15	1	05975-011-63-56	Strain Relief
16	1	05930-303-38-00	Limit Switch
17	2	05305-171-10-00	Limit Switch Mounting Screws
18	1	05700-003-58-50	Activator Weldment
19	1	05700-003-58-54	Limit Switch Actuator

---

## SECTION 6: PARTS SECTION

### DOOR ASSEMBLY

---

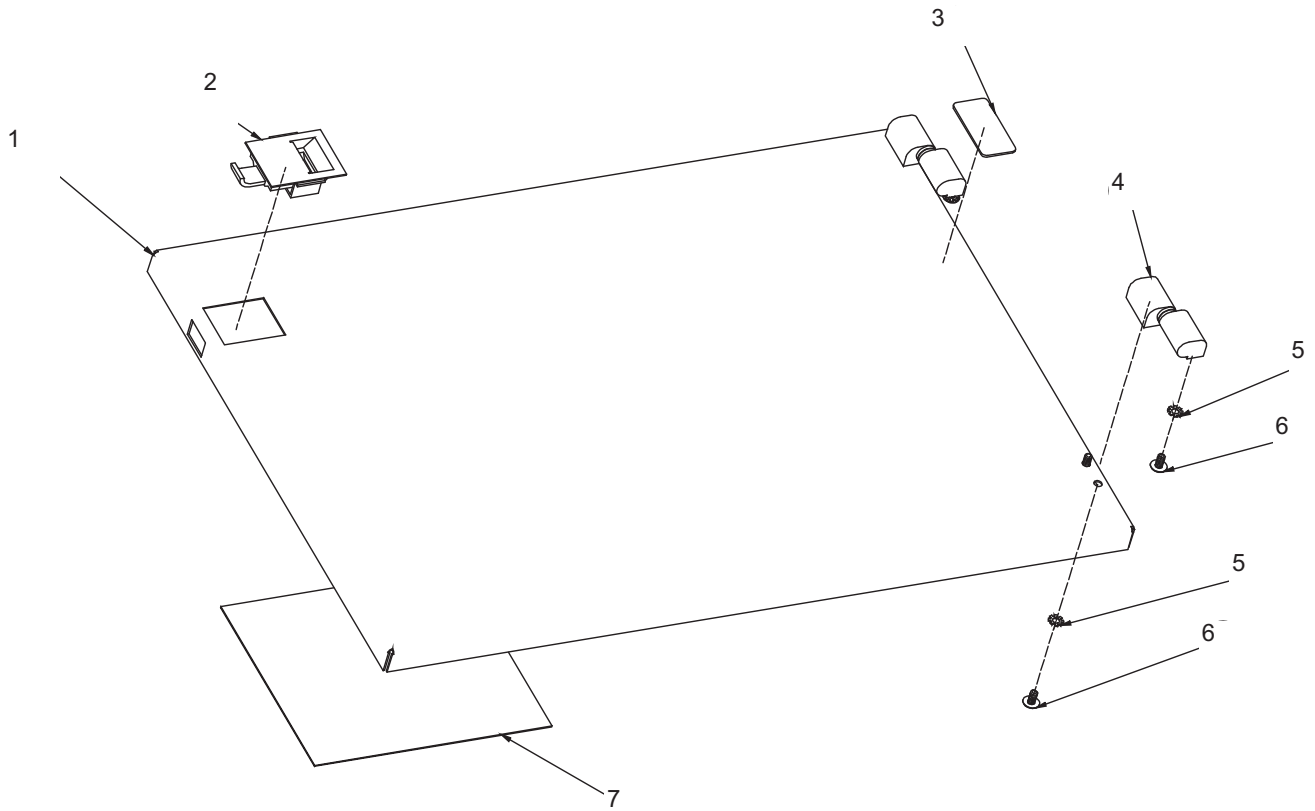

---

## SECTION 6: PARTS SECTION

### DOOR ASSEMBLY

Number	QTY	Part Number	Description
1	1	05700-002-24-40	Door Weldment
2	1	05340-001-96-30	Handle, Door Glasswasher
3	1	09905-011-61-70	Decal - Off/Fill/On
4	2	05340-021-62-04	Hinge
5	8	05311-273-02-00	Starwasher, External Tooth
6	8	05305-173-03-00	Screw 10-24 X 3/8
7	1	09905-021-64-88	Decal, Operating Instructions

---

# **SECTION 7: ELECTRICAL SCHEMATICS**

# SECTION 7: ELECTRICAL SCHEMATICS

## DELTA 115

### GLASSWASHER ELECTRICAL DIAGRAM

115 VOLT 60 HERTZ 1 PHASE (SOLID STATE)

#### LEGEND

L1 L2	POWER DISTRIBUTION BLOCK
GND	GROUND
H1	WASH TANK HEATER
R1	WASH HEATER CONTACTOR
R2	WASH TANK FILL RELAY
R3	WASH MOTOR CONTACTOR
M1	DRIVE MOTOR
M2	WASH PUMP MOTOR
DM	DETERGENT MOTOR
RM	RINSE AID MOTOR
SM	SANITIZER MOTOR
SC	SPEED CONTROL CIRCUIT BOARD
T1	CONTROL TRANSFORMER
S1	POWER SWITCH
S2	CONVEYOR LIMIT SWITCH
S3	DETERGENT MOTOR PRIME SWITCH
S4	RINSE AID MOTOR PRIME SWITCH
S5	SANITIZER MOTOR PRIME SWITCH
FS1	TOP FLOAT SWITCH
FS2	BOTTOM FLOAT SWITCH
TS1	WASH HEAT THERMOSTAT
CWV	COLD WATER VALVE
HWV	HOT WATER VALVE
CP	CAPACITOR
TB	TERMINAL BOARD
PB1	TEMP PROBE

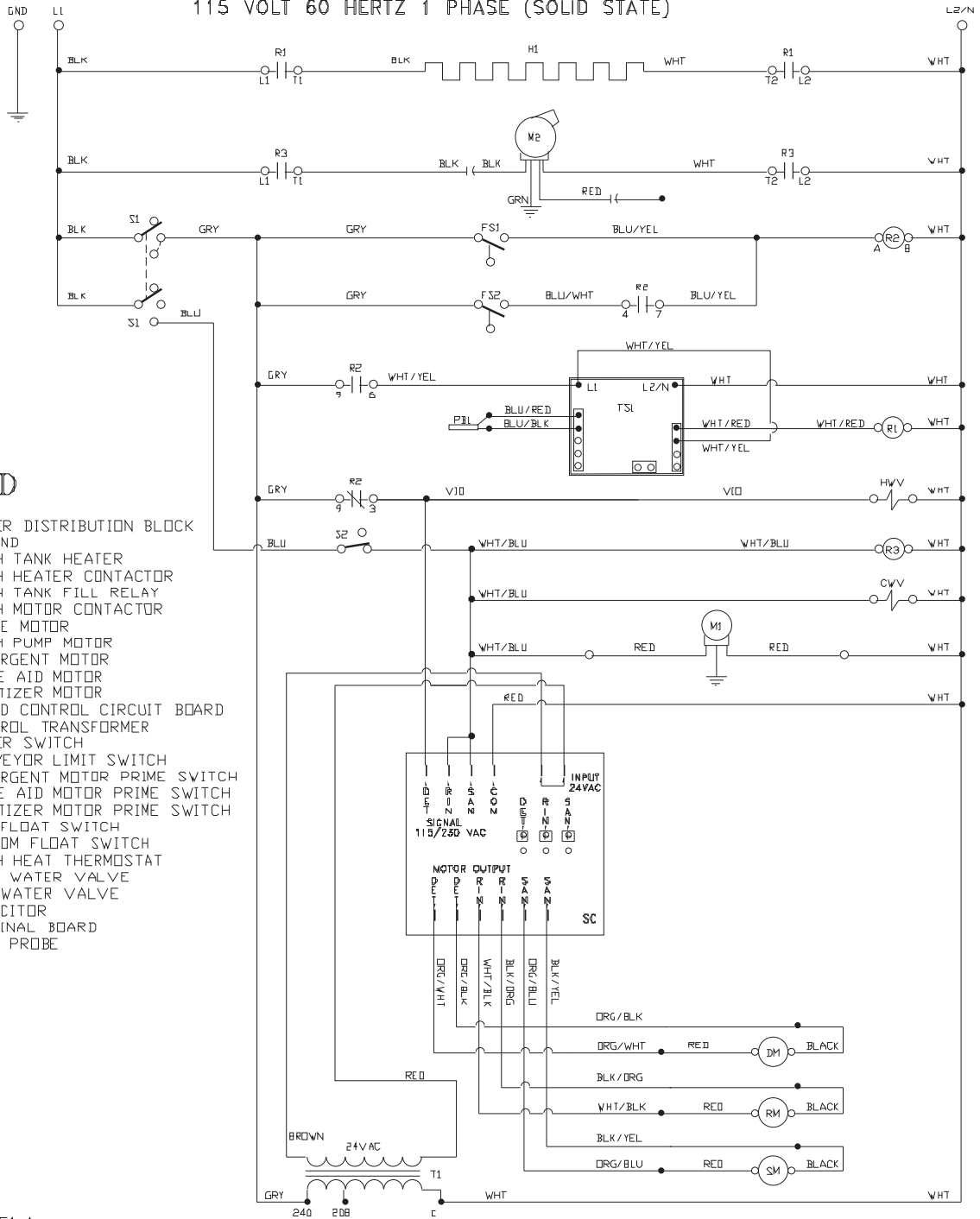

09905-004-27-51 A

# SECTION 7: ELECTRICAL SCHEMATICS

## DELTA 1200

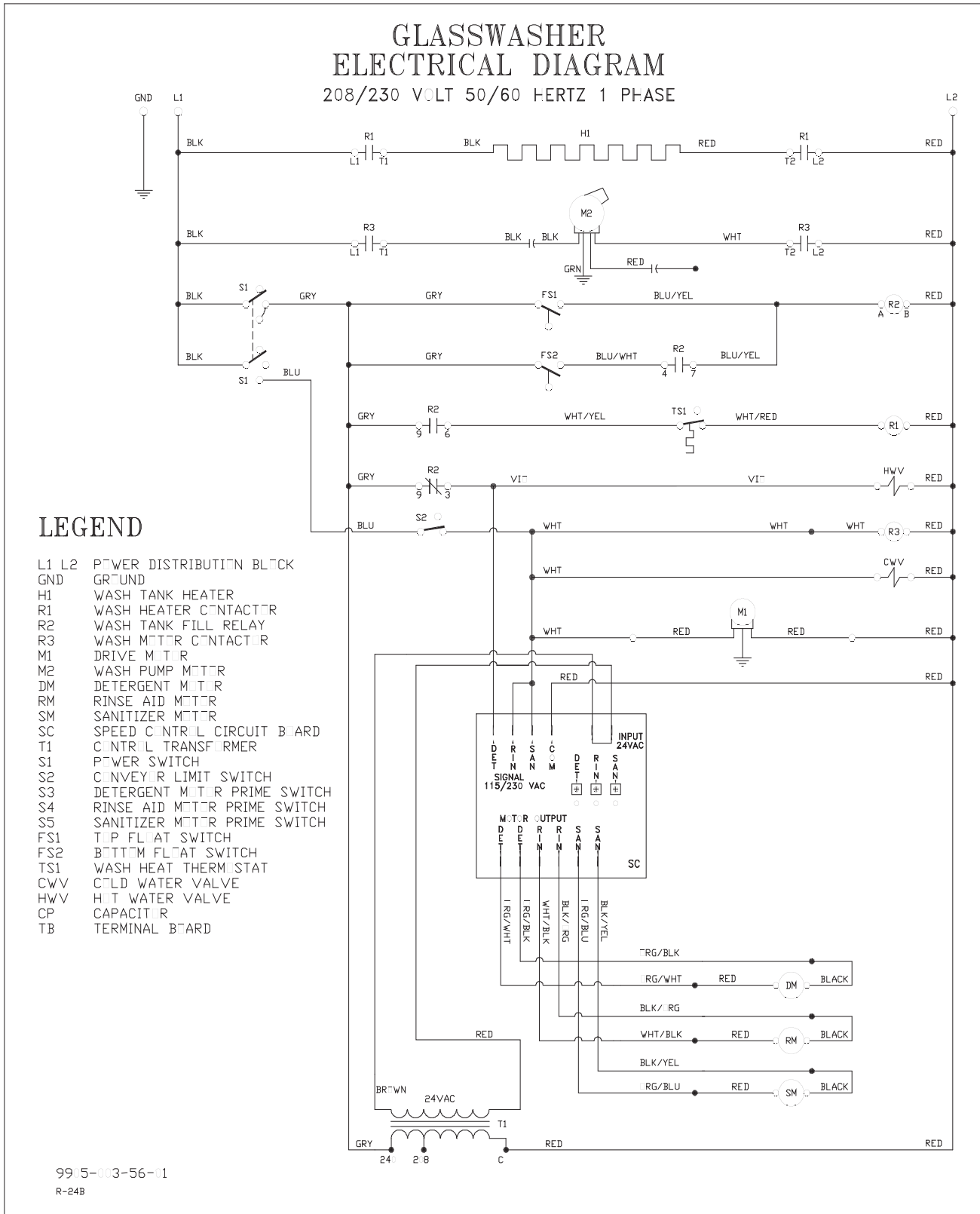

---

**Jackson<sup>®</sup>**  
***Warewashing Systems***

**TECHNICAL MANUAL**

FOR JACKSON MODELS:

**Delta<sup>®</sup> 115**

**Delta<sup>®</sup> 1200**

November 19, 2015  
P/N 07610-003-62-15 M

JACKSON WWS, INC.  
P.O. BOX 1060  
HIGHWAY 25E  
BARBOURVILLE, KY. 40906  
FAX: (606) 523-9196  
PHONE: (606) 523-9795  
[www.jacksonwws.com](http://www.jacksonwws.com)