



INSTALLATION, OPERATION, AND SERVICE MANUAL

**Noble I-E
Noble I-E-LTH
Noble I-HH**



REVISION HISTORY

Revision Letter	Revision Date	Made by	Applicable ECNs	Details
A	7-15-15	KAP	N/A	Release to production.
B	9-11-15	KAP	N/A	Added Sleeve Hood Spacer to parts breakdown on pg. 21.
C	3-9-16	JH	N/A	Corrected view on pg. 28 to show the gasket on top. Updated the view on pg. 21 to show the correct valve. Added Operating Times to pg. 3.
D	11-7-16	JH	8417	Changed timer from 05945-111-35-32 to 05945-004-11-78. Audited manual and corrected all incorrect P/Ns. Complete update of the manual to new format. Added I-HH to manual.
E	2-27-17	JH	8503	Changed inlet plumbing and air-gap to 3/4".
F	8-25-17	JH	N/A	Updated CAM Timer Operation, Filling the Wash Tub, and Delimiting Instructions to clarify initial fill and fill adjustments. Added drain solenoid assembly to Wash Sump Assembly Page.
G	12-14-17	JH	8551	Added the I-E-LTH to the manual.
H	5-8-18	JH	8604 8628	Added section on connecting heater contactor wires (LTH only) to pg. 12. Added item #9a to pgs. 27-28. Changed quantity of item #8 on pg. 33 to 2. Changed quantity of item #4 on pg. 50 to 1. Added item #16 to pgs. 50-51. Updated pg. 52 to show front dress panel. Updated schematic on pg. 56.



Noble I-E

Door-type dishmachine; chemical-sanitizing, single-rack.

Noble I-E-LTH

Door-type dishmachine; chemical-sanitizing, single-rack,
with booster heater.

Noble I-HH

Door-type dishmachine; chemical-sanitizing, single-rack
with high hood.

The manufacturer provides technical support for all of the dishmachines detailed in this manual. We strongly recommend that you refer to this manual before making a call to our technical support staff. Please have this manual open when you call so that our staff can refer you, if necessary, to the proper page. Technical support is not available on holidays.

Contact technical support toll-free at 1-888-800-5672.

Technical support is available to service personnel only.

TABLE OF CONTENTS

GUIDES

Symbols	1
Abbreviations & Acronyms	1

SPECIFICATIONS

I-E Dimensions	2
I-E-LTH Dimensions	3
I-HH Dimensions	4
Table Dimensions	5
Operating Capacities	6
Electrical Requirements	7

INSTALLATION

Installation Instructions	8
<i>Inspection</i>	8
<i>Unpacking</i>	8
<i>Leveling</i>	8
<i>Plumbing</i>	8
<i>Water Supply Connections</i>	8
<i>Pressure Regulator</i>	9
<i>Shock Absorber</i>	9
<i>Connecting the Drain Line</i>	9
<i>Plumbing Check</i>	9
<i>Electrical Power Connections</i>	10
<i>Ventilation</i>	10
<i>Thermostats</i>	10
<i>Voltage Check</i>	11
<i>Preparing Chemical Feeder Pumps</i>	11
<i>Priming Chemical Feeder Pumps</i>	11
<i>Heater Contactor Wires (I-E-LTH Only)</i>	12
<i>CAM Timer Operation</i>	13
<i>I-E/I-E-LTH False Panel Instructions</i>	15
<i>I-HH False Panel Instructions</i>	16

OPERATION

Operating Instructions	17
<i>Preparation</i>	17
<i>Power Up</i>	17
<i>Filling the Wash Tub</i>	17
<i>First Rack</i>	18
<i>Ware Preparation</i>	18
<i>Washing a Rack of Ware</i>	18
<i>Operational Inspection</i>	18
<i>Shutdown & Cleaning</i>	19
Delimiting Instructions	21

TABLE OF CONTENTS

MAINTENANCE

Preventative Maintenance	22
--------------------------------	----

TROUBLESHOOTING

Common Problems	23
-----------------------	----

PARTS

I-E Control Box	25
I-E-LTH Control Box	27
I-HH Control Box	29
Chemical Feeder Pump Components	32
I-E Hood Assembly	34
I-E-LTH Hood Assembly	36
I-HH Hood Assembly	38
I-E/I-E-LTH Door Assembly	40
I-HH Door Assembly	42
Wash Arm Assembly	44
Wash Manifold Assembly	45
Tub Assembly	46
Wash Sump Assembly	47
Spillway Assembly	48
Pump & Motor Assembly	49
I-E-LTH Booster Tank Assembly	50
Frame Assembly	52
Miscellaneous Parts	53

SCHEMATICS

I-E/I-HH 115 V, 60 Hz, 1-Phase	54
I-E/I-HH 208 V, 60 Hz, 1-Phase	55
I-E-LTH 208/230 V, 60 Hz, 1/3 Phase	56

SYMBOLS

- risk of injury to personnel.



- risk of damage to equipment.



- risk of electrical shock.



- caustic chemicals.



- reference data plate.



- lockout electrical power.

NOTICE - important note.

ABBREVIATIONS & ACRONYMS

ANSI - American National Standards Institute

CFM - Cubic Feet per Minute

GHT - Garden Hose Thread

GPH - Gallons per Hour

GPM - Gallons per Minute

GPG - Grains per Gallon

HP - Horse Power

Hz - Hertz

ID - Inside Diameter

kW - Kilowatts

NFPA - National Fire Protection Association

NPT - National Pipe Thread

PSI - Pounds per Square Inch

V - Volts

SPECIFICATIONS

I-E DIMENSIONS

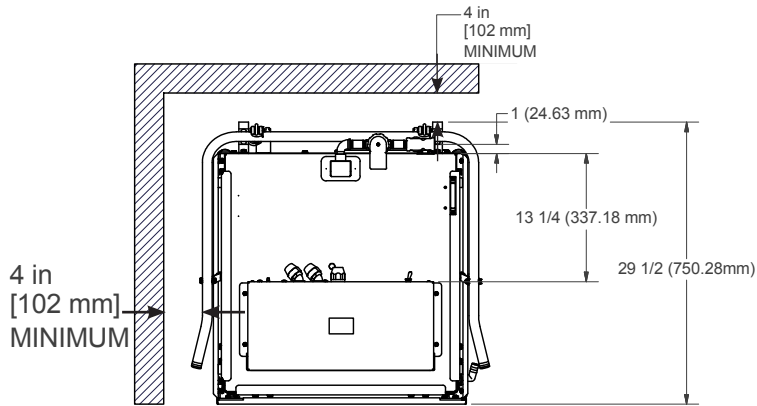

All dimensions from the floor can be increased 1 1/2" using the machine's adjustable feet.

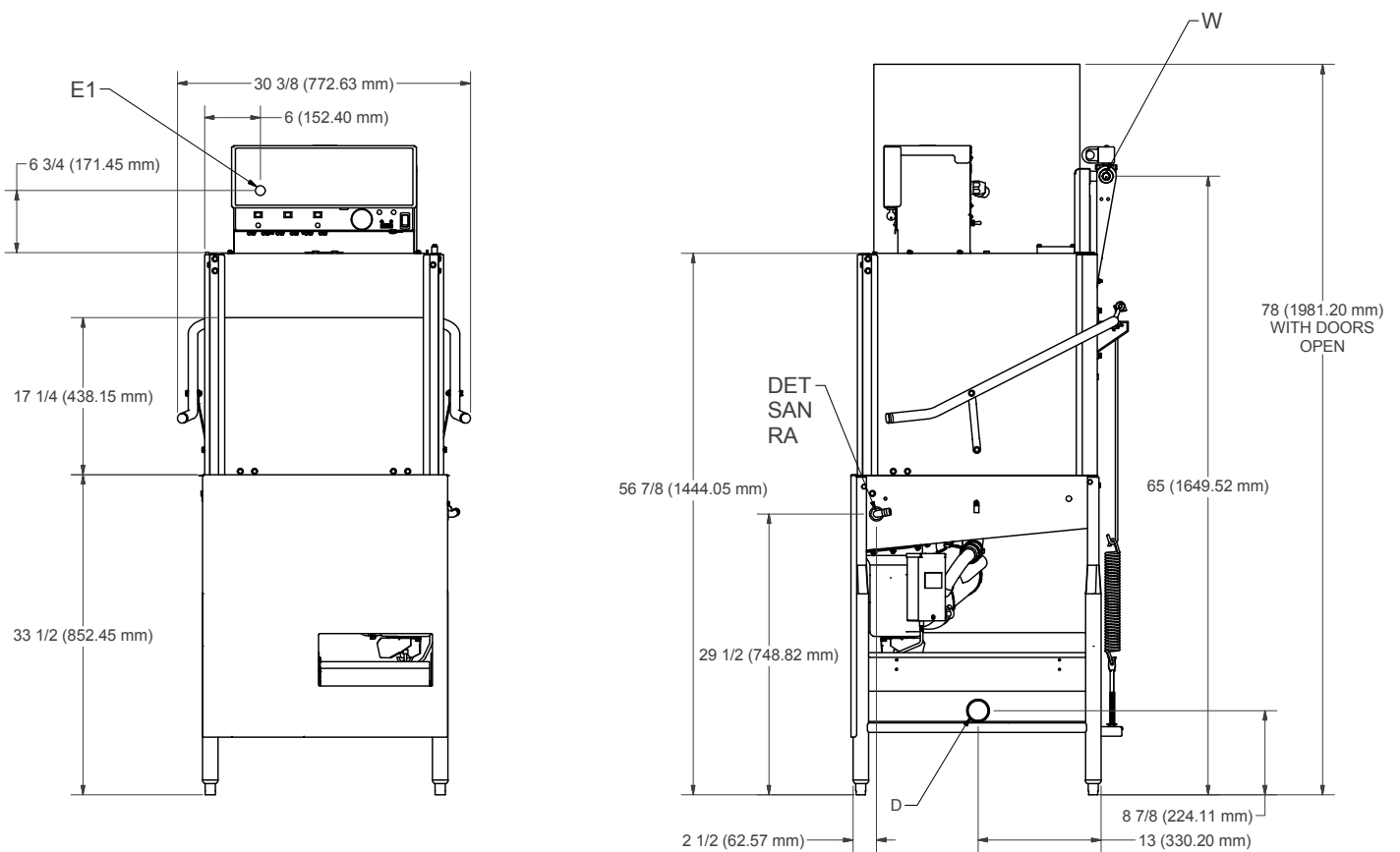

E1	MAIN ELECTRICAL CONNECTION (1 1/8" HOLE) (Located on back of control box)
W	MAIN INLET WATER CONNECTION (3/4" NPT)
D	DRAIN CONNECTION (2" NPT)
DET	DETERGENT BULKHEAD ACCESS (7/8" HOLE)
SAN	SANITIZER INLET
RA	RINSE-AID INLET

SPECIFICATIONS

I-E-LTH DIMENSIONS

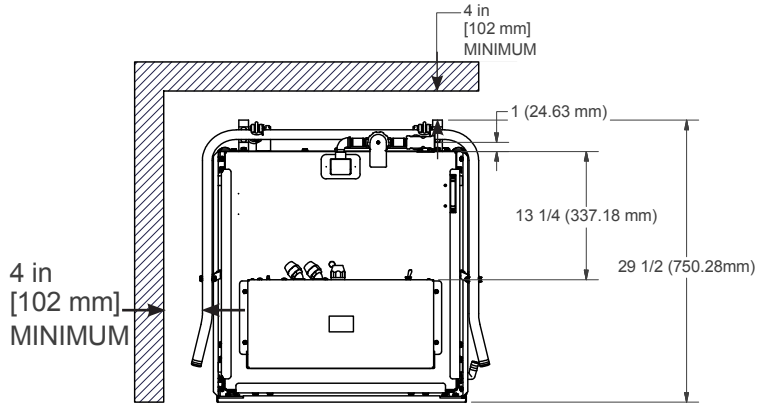

All dimensions from the floor can be increased 1 1/2" using the machine's adjustable feet.

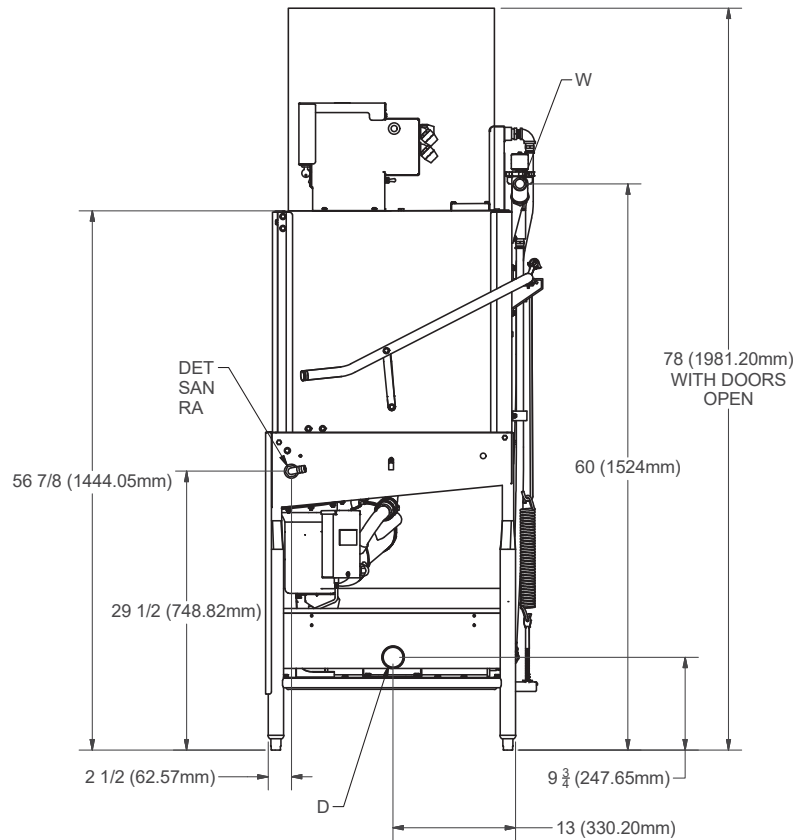
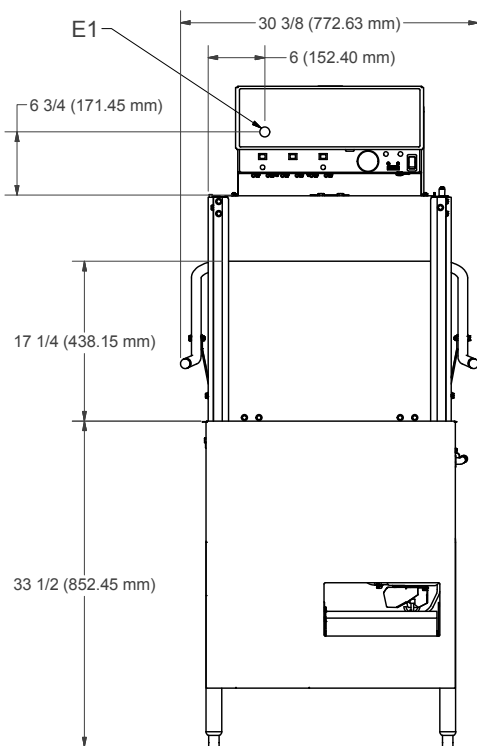

E1	MAIN ELECTRICAL CONNECTION (1 1/8" HOLE) (Located on back of control box)
W	MAIN INLET WATER CONNECTION (3/4" NPT)
D	DRAIN CONNECTION (2" NPT)
DET	DETERGENT BULKHEAD ACCESS (7/8" HOLE)
SAN	SANITIZER INLET
RA	RINSE-AID INLET

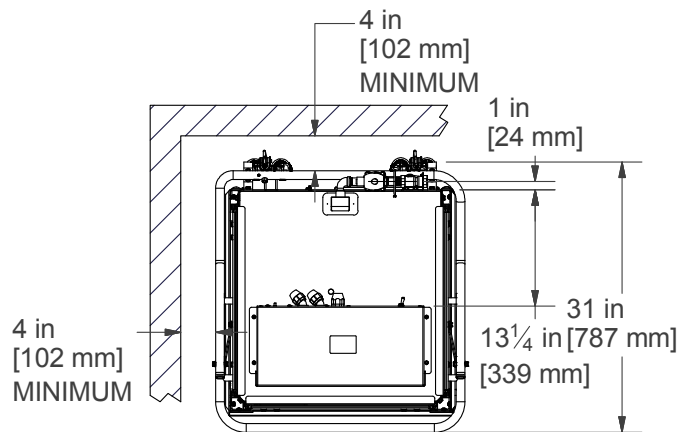

All dimensions from the floor can be increased 1 1/2" using the machine's adjustable feet.

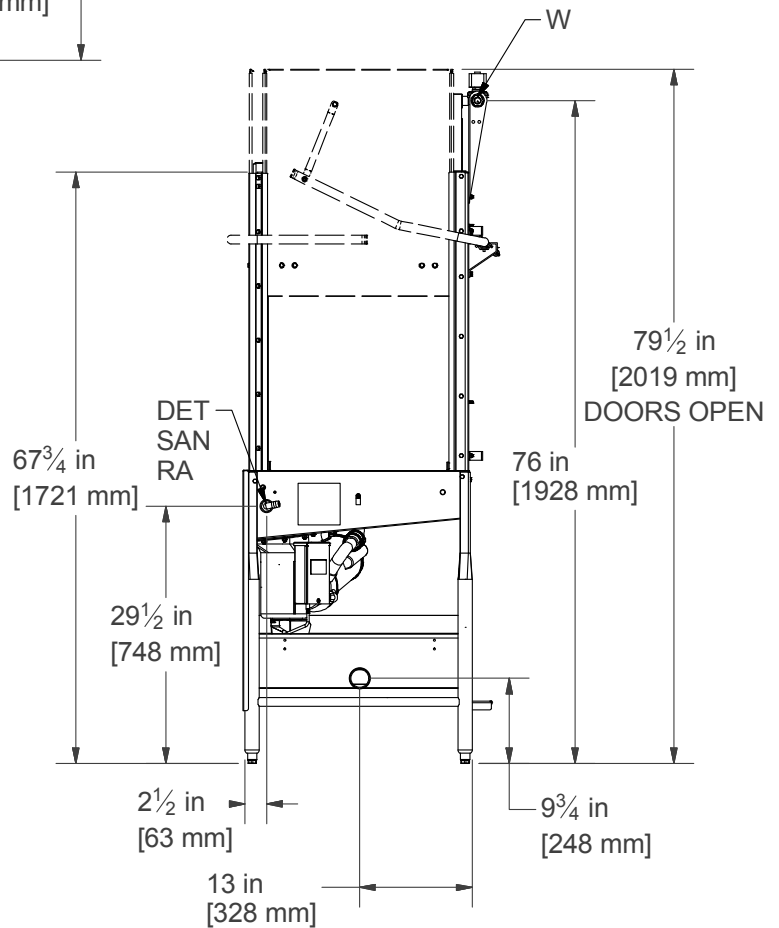
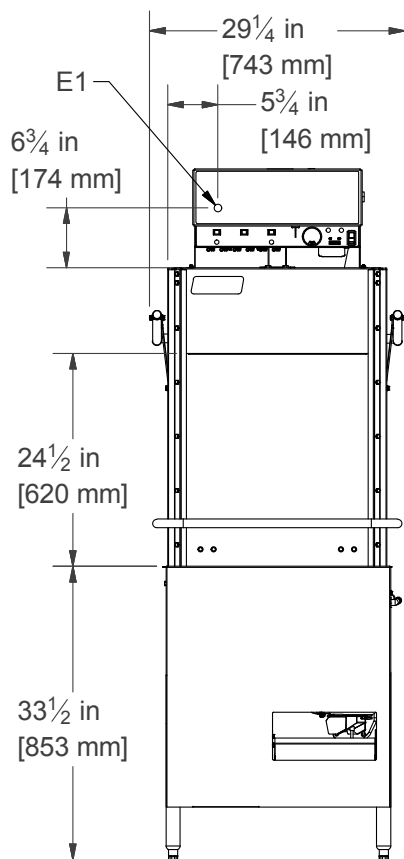

E1	MAIN ELECTRICAL CONNECTION (1 1/8" HOLE) (Located on back of control box)
W	MAIN INLET WATER CONNECTION (3/4" NPT)
D	DRAIN CONNECTION (2" NPT)
DET	DETERGENT BULKHEAD ACCESS (7/8" HOLE)
SAN	SANITIZER INLET
RA	RINSE-AID INLET

NOTICE Please remove the front dress panel from the dishwasher if mounting dishwasher for a corner installation and attaching side tables. Corner installation will trap panel making it difficult to remove.

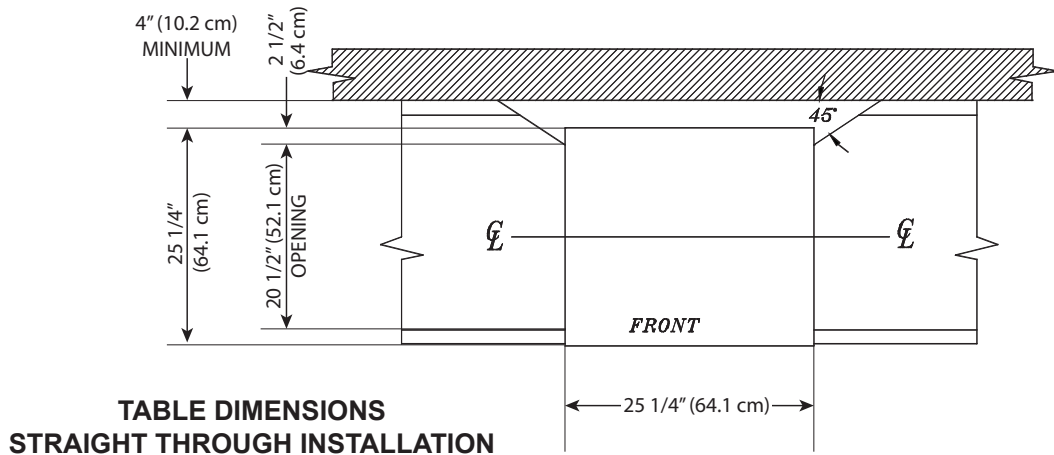
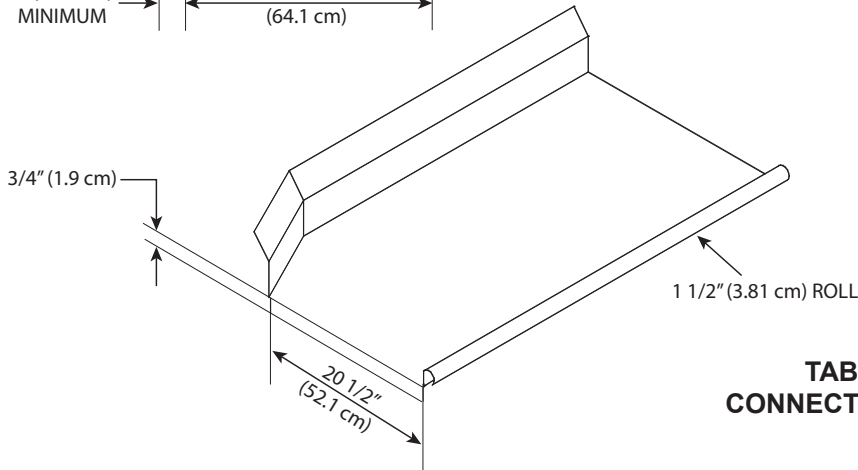
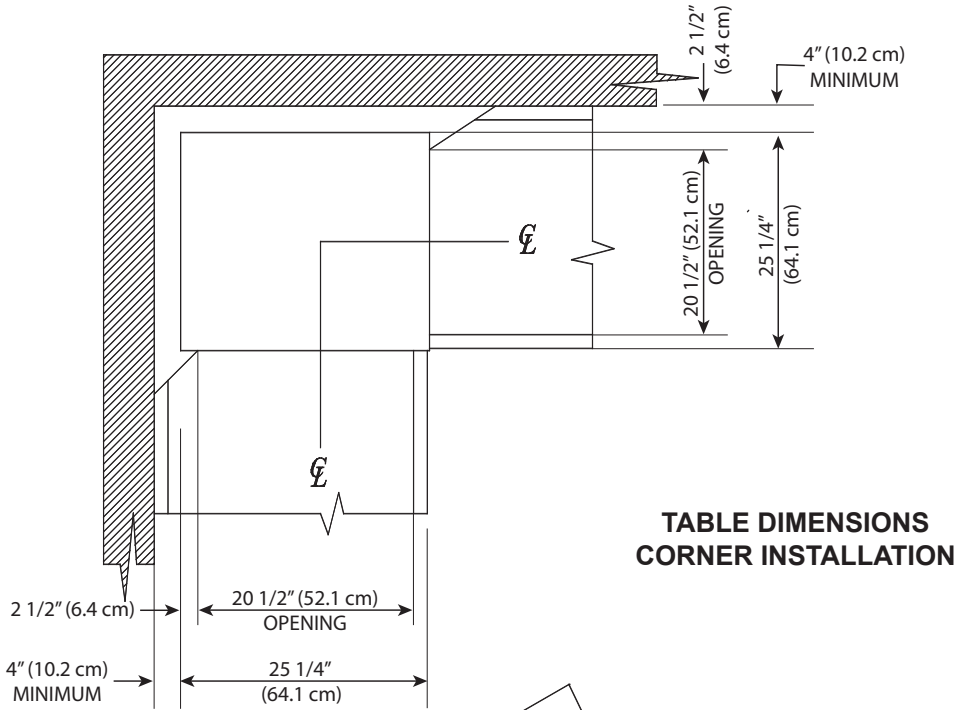

SPECIFICATIONS

OPERATING CAPACITIES

Model Designation:	I-E	I-E-LTH			I-HH
Operating Capacity:					
Racks per Hour	39	39			39
Dishes per Hour	975	975			975
Glasses per Hour	1404	1404			1404
Tank Capacity (Gallons):					
Wash Tank	1.02 (40.2 GPH)	1.02 (40.2 GPH)			1.61 (62.8 GPH)
Electrical Loads (as applicable):					
Wash Motor HP	1	1			1
Operating Times (seconds):					
		Normal	Medium	Heavy	
Wash	42	42	100	280	43
Rinse	25	25	25	25	25
Dwell	20	20	20	20	18
Water Temperatures (°F):					
<i>Minimum Wash Temperature</i>	120	120			120
<i>Recommended Wash Temperature</i>	N/A	140			N/A
<i>Minimum Rinse Temperature</i>	120	120			120
<i>Recommended Rinse Temperature</i>	N/A	145			N/A
<i>Minimum Incoming Water Temperature</i>	120	110			120
Other Water Requirements:					
<i>Water Flow Pressure (PSI)</i>	20 +/- 5	20 +/- 5			20 +/- 5
<i>Flow Rate Minimum (GPM)</i>	6.18	6.18			9.66
<i>Water Line Size (NPT)</i>	3/4"	3/4"			3/4"
<i>Drain Line Size (NPT)</i>	2"	2"			2"
<i>Minimum Chlorine Required (PPM)</i>	50	50			50

NOTICE Always refer to the machine data plate for specific electrical and water requirements.
The material provided on this page is for reference only and is subject to change without notice.

NOTICE



All electrical ratings provided in this manual are for reference only. Always refer to the machine data plate to get exact electrical information for this machine. **All electrical work performed on machines should be done in accordance with applicable local, state, territorial, and national codes.** Work should only be performed by qualified electricians and authorized service agents.

Note that all electrical wiring used in this series of machines must be rated, at a minimum, for 212 °F (100 °C), and that only copper conductors must be used.

Where applicable, heating element amperage draws have been adjusted for the assumed input voltage. The manufacturer assumes incoming voltages will be either 115, 208, 230, or 460 Volts. Some heating elements used in the machines are rated for other voltages, such as 240 Volts and 480 Volts. Always verify the amperage draw of the machine in operation when sizing circuit protection.

Available Electrical Characteristics:

I-E/I-HH

Electrical Characteristics

VOLTS	115	208
PHASE	1	1
FREQ	60	60
WASH MOTOR AMPS	10.0 A	5.0 A
TOTAL LOAD	10.0 A	5.0 A

I-E-LTH

Electrical Characteristics

VOLTS	208	230	208	230
PHASE	1	1	3	3
FREQ	60	60	60	60
WASH MOTOR AMPS	5.0 A	5.0 A	5.0 A	5.0 A
RINSE HEATER AMPS	43.3 A	47.8 A	25.0 A	27.7 A
TOTAL LOAD	48.3 A	52.8 A	30.0 A	32.7 A

INSPECTION

Do not throw away the container if damage is evident!

Before installing the unit, check the packaging and machine for damage. If the packaging is damaged, the machine might also be damaged. If there is damage to both the packaging and machine, do not throw away the packaging. The dishmachine has been inspected and packed at the factory and is expected to arrive to you in new, undamaged condition. However, rough handling by carriers or others might result in damage to the unit while in transit. If so, do not return the unit to the manufacturer; instead, contact the carrier and ask them to send a representative to the site to inspect the damage and complete an inspection report. You must contact the carrier and the dealer that sold you the unit within 48 hours of receiving the machine.

UNPACKING

While removing the machine from the packaging, ensure that there are no missing parts. If an item is missing, contact the manufacturer immediately.

LEVELING

The dishmachine must be level in its operating location to prevent damage to the machine during operation and to ensure the best results. The unit comes with four adjustable bullet feet, which can be turned using a pair of channel locks (or by hand if the unit can be raised safely). Ensure that the unit is level from side-to-side and front-to-back before making any connections.

PLUMBING

The plumber MUST flush the incoming water line!

Plumbing connections must comply with all applicable local, state, and national plumbing codes. The plumber is responsible for ensuring that the incoming water line is thoroughly flushed before connecting it to any component of the dishmachine. It is very important to remove all foreign debris from the water line that might potentially get trapped in the valves or cause an obstruction. Any valves that are fouled as a result of foreign matter left in the water line—and any expenses resulting from this fouling—are not the responsibility of the manufacturer.

A water hardness test must be performed.

A water hardness test must be performed. A hardness test kit can be found on the warning tag that is attached to the incoming plumbing connection on the back of the machine. If water hardness is higher than 3 GPG, install a water softener or install the optional HTS-11 (scale prevention and corrosion control). Please contact the manufacturer to purchase the HTS-11.

**WATER SUPPLY CONNECTION:
WATER HARDNESS HIGHER THAN
3 GPG**

If water hardness is higher than 3 GPG and a water softener is not being used, install the HTS-11 into the water line before the dishmachine's incoming water connection point using copper pipe. Observe proper inlet/outlet water directions. Flow directions are molded into the top of the head. It is recommended that a water shut-off valve be installed before installing the HTS-11 to allow access for service. Plumb from the HTS-11 outlet to the incoming water connection point using copper pipe (or order the flexible hose kit offered by manufacturer).

**WATER SUPPLY
CONNECTION:
WATER HARDNESS
OF 3 GPG
OR LOWER**

If water hardness tests at 3 GPG or lower, install the water supply line to the dishmachine's incoming water connection point using copper pipe (or order the flexible hose kit offered by the manufacturer). It is recommended that a water shut-off valve be installed in the water line between the main supply and the machine to allow access for service.

**PRESSURE
REGULATOR**

The manufacturer has an optional water pressure regulator to accommodate areas where water pressure fluctuates or is higher than the recommended pressure. Take care not to confuse static pressure with flow pressure: static pressure is line pressure in a "no flow" condition (all valves and services are closed); flow pressure is the pressure in the fill line when the valve is opened during the cycle.

*Take care not to confuse
static pressure with
flow pressure!*

SHOCK ABSORBER

It is suggested that a shock absorber (not supplied) be installed on the incoming water line. This prevents water hammer (hydraulic shock)—induced by the solenoid valve as it operates—from causing damage to the equipment.

**CONNECTING THE
DRAIN LINE**

The drains for the models covered in this manual are gravity discharge drains. All piping to the machine must be 2" NPT and must not be reduced. There must also be an air-gap between the machine drain line and the floor sink or drain. If a grease trap is required by code, it should have a flow capacity of 5 GPM.

PLUMBING CHECK

After installing the incoming fill line and drain line, slowly turn on the water supply to the machine. Check for any leaks and repair as required. All leaks must be repaired before operating the machine.

ELECTRICAL POWER CONNECTIONS



Disconnect electrical power at the breaker or disconnect switch and tag-out in accordance with procedures and codes.

Electrical and grounding connections must comply with the applicable portions of the National Electrical Code ANSI/NFPA 70 (latest edition) and/or other electrical codes.

Disconnect electrical power supplies and place a tag at the disconnect switch to indicate that you are working on the circuit.

Refer to the data plate for machine operating requirements, machine voltage, total amperage load, and serial number.

The main power terminal blocks (for the dishmachine and for the rinse booster heater, if applicable) are located at the top of the machine. You will have to remove the top cover to access these connections. Route incoming power lines within conduit that will connect via fittings to the pre-punched holes in the back of the Control Box. Install power and ground wires to lugs as indicated by the appropriate decals in the control box. Use copper conductors only. Use of an anti-oxidation agent is permissible on the power connections. Tighten all connections.



Verify the incoming voltage matches the voltage indicated on the decal next to the incoming power pre-punched hole.

NOTICE *It is recommended that “DE-OX” or similar anti-oxidation agent be used on all power connections.*

VENTILATION

The dishmachine should be located with an adequate exhaust hood or ventilation system with provisions for venting. This is essential to permit efficient removal of the condensation exhaust. Ensure that the exhaust system complies with applicable codes and standards.

NOTICE *Any damage that is caused by steam and/or moisture due to improper ventilation is NOT covered under the warranty.*

Dishmachine ventilation requirements:

200 CFM

The exhaust system must be sized to handle this volume for the dishmachine to operate properly.

THERMOSTATS

The thermostats on this dishmachine have been set at the factory. They should only be adjusted by an authorized service agent.

VOLTAGE CHECK



1. Ensure the power switch is in the OFF position and apply power to the dishmachine.
2. Check the incoming power at the terminal block and ensure it corresponds to the voltage listed on the data plate. If not, contact a qualified service agency to examine the problem.

CAUTION! Do not run the dishmachine if the voltage is too high or too low (refer to applicable electrical codes).

3. Shut off the service breaker and mark it as being for the dishmachine.
4. Advise all proper personnel of any problems and of the location of the service breaker. Replace the control box cover and tighten-down the screws.

PREPARING CHEMICAL FEEDER PUMPS

These dishmachines are supplied with detergent, rinse-aid, and sanitizer chemical feeder pumps.

Locate the open ends of the chemical tubes with the tube stiffeners and place each one in the appropriate container.

- A. Red Tubing = Detergent
- B. Blue Tubing = Rinse-aid
- C. White Tubing = Sanitizer



CAUTION! Chlorine-based sanitizers can be detrimental to this machine if the chemical solution is too strong. See a chemical professional to ensure the dispenser is set-up correctly.

PRIMING CHEMICAL FEEDER PUMPS



Chemical feeder pumps need priming when the machine is first installed or if the chemical lines have been removed and air was allowed to enter.

CAUTION! Water must be in the sump and wash tank before chemicals are dispensed.

1. Verify that the proper chemical tube stiffener inlet is in the proper container.
2. Use the toggle switches on the front of the control box to prime each pump. There are three switches mounted by the peristaltic pumps. One will prime the detergent, the second will prime the rinse-aid, and the third will prime the sanitizer.
3. To prime the pumps, hold the switch in the momentary position until the chemical can be observed entering the sump.
4. Detergent is dispensed as required by the timer during the wash cycle. The amount of detergent might need to be increased or decreased depending on water quality and type of detergent.

PRIMING CHEMICAL FEEDER PUMPS



WARNING! Some of the chemicals used in dishwashing might cause chemical burns if they come in contact with skin. Wear protective gear when handling these chemicals. If any contact with skin occurs, immediately follow the treatment instructions provided with the chemicals.

- Rinse-aid is dispensed as required into the final rinse. The amount of rinse-aid might need to be adjusted depending on water hardness and results.



- Sanitizer is dispensed into the final rinse. The amount of sanitizer might need to be adjusted depending on the concentration and type of sanitizer used.



- Refer to CAM Timer Operation section for instructions on adjusting the chemical feeder pumps.



HEATER CONTACTOR WIRES (LTH ONLY)



Heater contactor wires must NOT be connected before water fills the unit the first time!

- Disconnect electrical power at the breaker or disconnect switch and tag-out in accordance with procedures and codes.
- Remove the control box top.
- Locate the loose connector with the orange/white and blue/black wires.
- Plug the loose connector into the empty connector on the right side of the ELAN thermostat board.

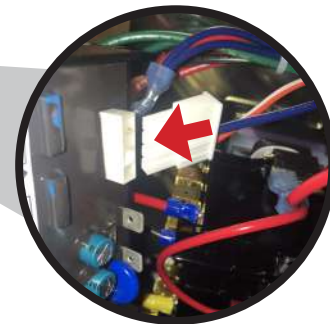
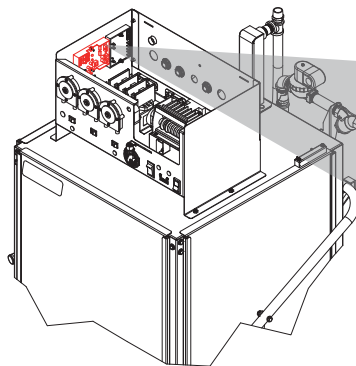

- Replace the control box top.
- Reconnect electrical power at the breaker or disconnect switch in accordance with procedures and codes.

CAM TIMER OPERATION

The CAM timer is a 1-minute, 30-second, 8-CAM timer that controls the operation of the dishwasher. The following is a description of the setpoints for each CAM and the function of each switch.

CAM 1 is a cut CAM with a single notch that serves as the cycle control.

FUNCTION: When the machine is in operation mode the notch is in the home position. The machine will remain idle until the door is opened, then CAM 1 moves to the start position and holds until the door is closed. The closing of the door will start the next cycle. The CAM will rotate a complete cycle and return to the home position and hold.

CAM 2 is the reset CAM.

CAM 3 is a cut CAM that provides the wash cycle timing.

FUNCTION: The wash CAM works off the normally-open contacts of CAM 3. This requires the microswitch to be held closed by the CAM. It will close and energize the wash pump two seconds after the cycle switch is activated. The pump will operate through the wash cycle then shut down for the dwell period. As the CAM rotates, it energizes the pump for the rinse cycle. When CAM 1 reaches its home position it will de-energize CAM 3, shutting down the wash pump.

The last 5 CAMs are adjustable. The following instructions will require that the timer position have the CAMs to the front and the motor to the left as shown below.

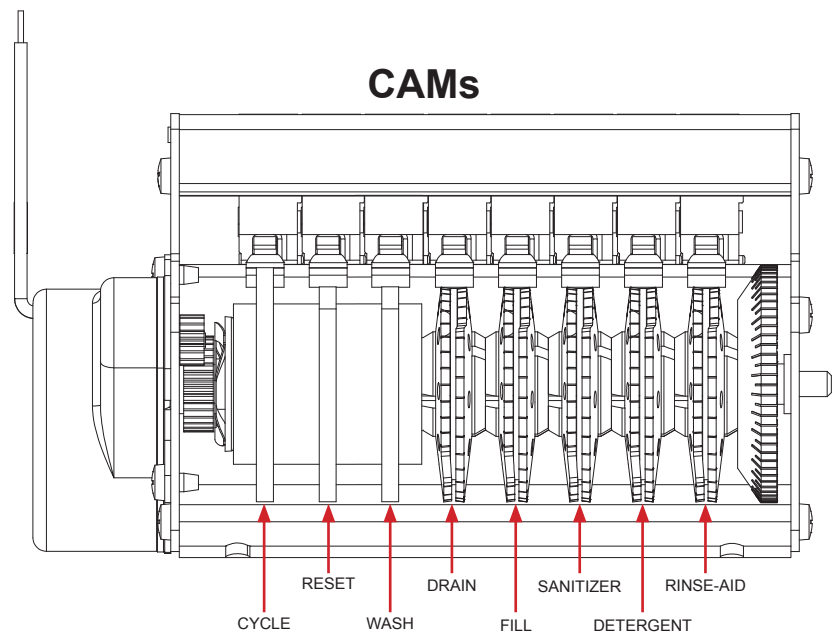

CAM 4 is an adjustable CAM that controls the drain valve.

FUNCTION: The drain solenoid CAM works off the normally-closed contacts of CAM 4. When the cycle starts, the switch is held open until it drops into the notch of the CAM. This energizes the drain solenoid, which drains the machine. After a 12-second delay, the CAM reverses the switch, de-energizing the drain solenoid. This CAM might need adjusted depending on water pressure. The drain solenoid must remain open long enough to drain the machine.

SETTINGS: The right side of CAM 4 must be set to pick up the switch just before the wash/rinse cycle CAM switch drops. It will hold the drain solenoid open to drain the tank during the dwell period. Adjustments to drain time are made with the left side of CAM 4. The CAM must be moved back into the wash time until all water is being drained from the machine.

CAM TIMER OPERATION

CAM 5 is an adjustable CAM that controls the fill valve and the amount of water used.

For lowest energy use, adjust CAM 5 so water level matches level shown in Filling the Wash Tub section.

FUNCTION: The fill solenoid CAM works off the normally-closed contacts of CAM 5. The switch is held open by the CAM until it drops into the notch of the CAM. This energizes the fill solenoid, which starts filling the machine with water. After a 10-second delay, the CAM reverses the switch, de-energizing the fill solenoid. This CAM might need adjusted depending on water pressure. The fill solenoid must remain open long enough to fill the machine to the correct level (see Filling the Wash Tub section).

SETTINGS: The right side of CAM 5 must be set to allow the switch to drop two seconds before the drain solenoid is de-energized to ensure the detergent residue is flushed from the machine. It will hold the fill solenoid open until the CAM switch arm is raised. At that time the fill solenoid is de-energized, shutting off the incoming water. If the tub isn't filled to the correct level, the fill time needs adjusted. Adjustments to fill time are made with the left side of CAM 5. To increase the water level, open the notch of the CAM. To decrease the water level, close the notch.

CAM 6 is an adjustable CAM that controls the sanitizer pump.

FUNCTION: The sanitizer pump CAM works off the normally-closed contacts of CAM 6. The switch is held open by the CAM until it drops into the notch of the CAM. This energizes the sanitizer pump. The time the pump remains energized must be determined in the field to suit water conditions and the chemical used.

SETTINGS: The left side of CAM 6 must be set to allow the switch to drop in past the starting point of the fill CAM and after the drain solenoid has closed. Adjustments to sanitizer time are made with the right side of CAM 6. To increase the sanitizer time, open the notch of the CAM. To decrease, close the notch in small increments until the correct level is reached.

CAM 7 is an adjustable CAM that controls the detergent pump.

FUNCTION: The detergent pump CAM works off the normally-closed contacts of CAM 7. The switch is held open by the CAM until it drops into the notch of the CAM. This energizes the detergent pump. The time the pump remains energized must be determined in the field to suit water conditions and the chemical used.

SETTINGS: The left side of CAM 7 must be set to drop in past the starting point of the wash pump CAM. Adjustments to detergent time are made with the right side of CAM 7. To increase the detergent time, open the notch of the CAM. To decrease, close the notch in small increments until the correct level is reached.

CAM 8 is an adjustable CAM that controls the rinse-aid pump.

FUNCTION: The rinse-aid pump CAM works off the normally-closed contacts of CAM 8. The switch is held open by the CAM until it drops into the notch of the CAM. This energizes the rinse-aid pump. The time the pump remains energized must be determined in the field to suit water conditions and the chemical used.

SETTINGS: The left side of CAM 8 must be set to drop in past the starting point of the fill CAM after the drain solenoid has closed. Adjustments to rinse-aid time are made with the right side of CAM 8. To increase the rinse-aid time, open the notch of the CAM. To decrease, close the notch in small increments until the correct level is reached.

False Panel Weldment
05700-002-51-66

False Panel Kit
05700-003-12-93

Rack rail removed and repositioned
for a corner operation

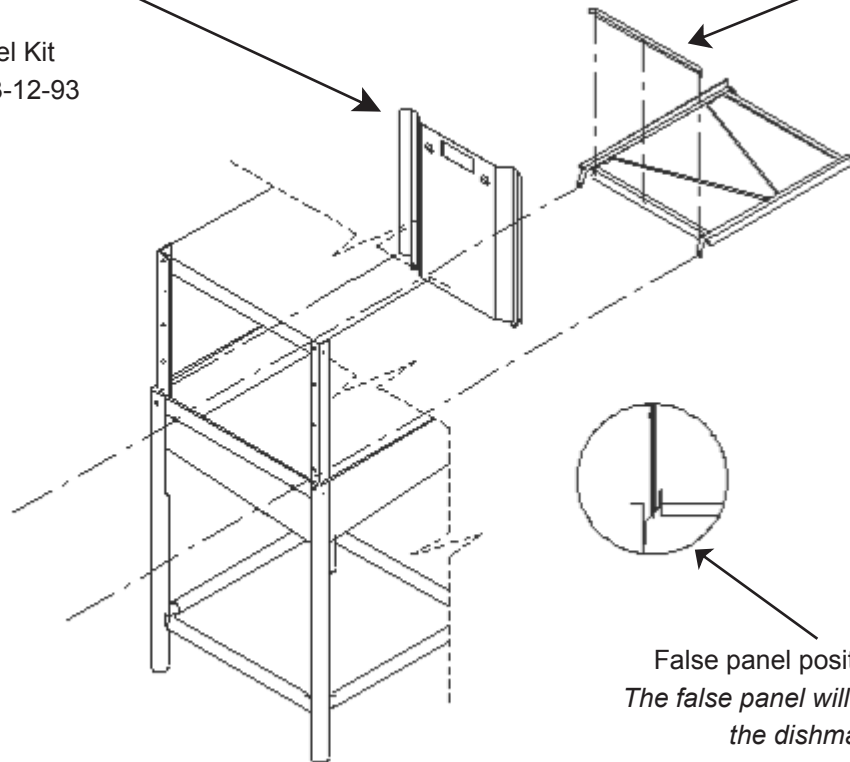

False panel positioned in unit.
*The false panel will mount inside of
the dishmachine.*

Insert this side first

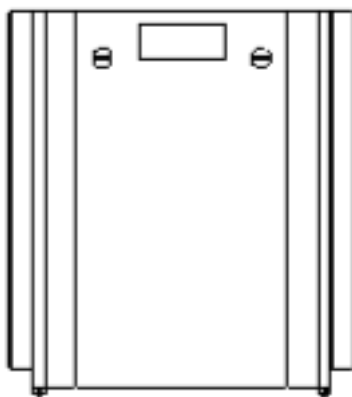

Bottom of side panel

1. Remove the rack assembly from the dishmachine.
2. Position the panel in the dishmachine on the side to be closed.
3. Hold the panel against the side of the dishmachine and push upward.
4. The panel will clip in at the top, inside of the unit.
5. The holes in the false panel will line up with the rack assembly holes.
6. Reinstall the screws for the rack assembly which will secure the false panel to the unit.
7. Reassemble the rack track in an "L" shape for a corner operation.

False Panel Weldment
05700-002-52-54

False Panel Kit
05700-002-52-89

Rack rail removed and
repositioned for a
corner operation.

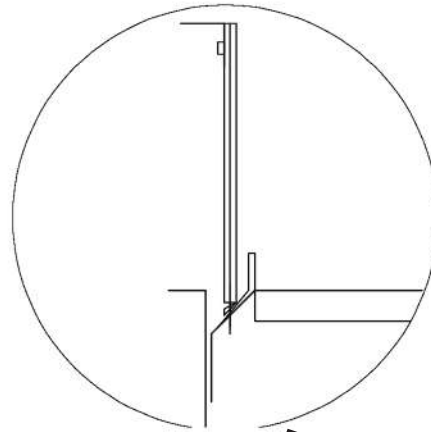
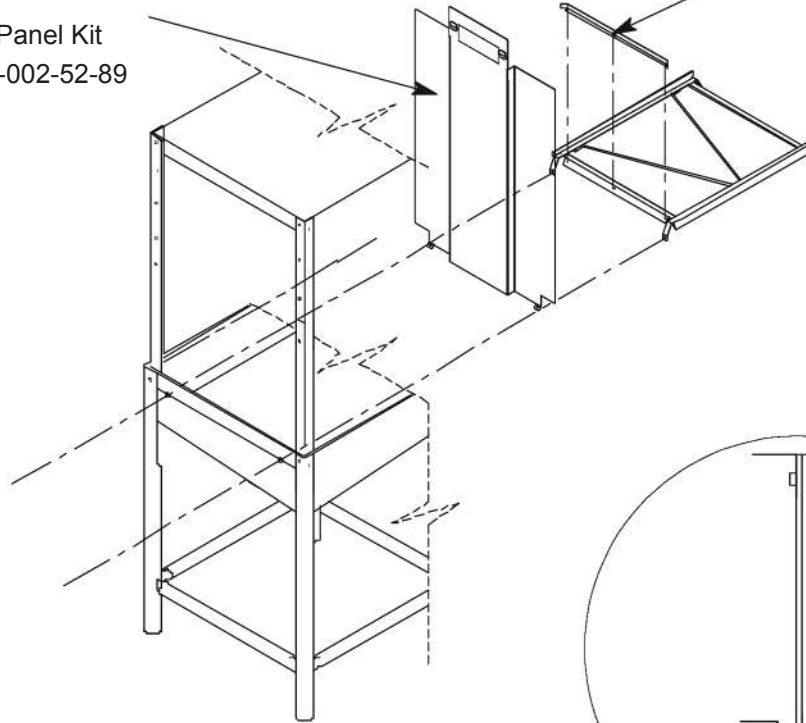

False panel positioned in unit.
*The false panel will mount inside of
the dishmachine.*

Insert this
side first.

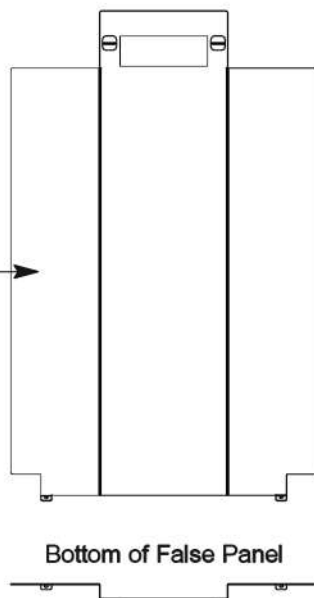

1. Remove the rack assembly from the dishmachine.
2. Position the panel in the dishmachine on the side to be closed.
3. Hold the panel against the side of the dishmachine and push upward.
4. The panel will clip in at the top, inside of the unit.
5. The holes in the false panel will line up with the rack assembly holes.
6. Reinstall the screws for the rack assembly which will secure the false panel to the unit.
7. Reassemble the rack track in an "L" shape for a corner operation.

PREPARATION Before operating the unit, verify the following:

1. The sump strainer and pan strainer are in place and clean.

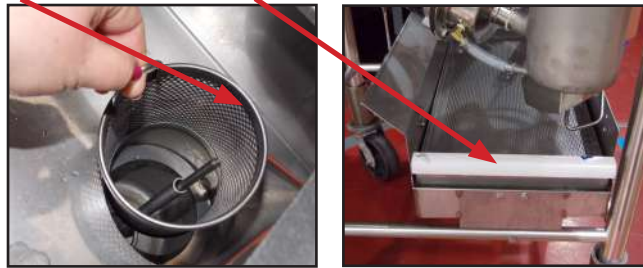

2. The drain stopper is installed.



3. The wash/rinse arms are installed and secure.



POWER UP To place the unit in standby, flip the "OFF/ON/FILL" switch to the ON position.

FILLING THE WASH TUB

1. For the initial fill (installation or beginning of day), close the door and depress and hold the "OFF/ON/FILL" switch in the FILL position for approximately 8-10 seconds.
2. Open the door and verify water level is correct. Water must be between the lines on the drain stopper. For lowest energy use, water should be at the lowest line on the drain stopper. This is only necessary during the initial fill. After this, the water level is controlled by the timer.

If water level needs adjusted, see the CAM Timer Operation section and follow the instructions for CAM 5.

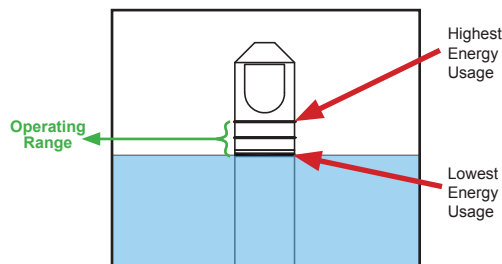

FILLING THE WASH TUB

3. Verify that the drain stopper is preventing the wash tub water from pouring out excessively. There might be some slight leakage from the drain hole. Verify that there are no other leaks on the unit before proceeding any further.
4. The wash tub must be completely filled before operating the wash pump to prevent damage to components.
5. Once the wash tub is filled, the unit is ready for operation.

FIRST RACK

The first rack of ware that you place into the unit can have the effect of quickly reducing the temperature of the wash tank. This is because you are introducing cold materials into the dishwasher and the unit has to circulate water to activate the heating cycle. You might have to run the first rack through the unit again. Any time the unit has not been operated for an extended period of time this is possible, but unlikely. This is usually dependent on the type of ware you are using, its temperature, and the ambient temperature of the kitchen area. To ensure proper operation, always observe the temperatures of the wash and rinse when first starting the unit.

WARE PREPARATION

Proper preparation of ware is essential for the smooth, efficient operation of your dishwasher. If done properly, you can expect to have fewer re-washes and use substantially less detergent. Any ware placed inside the machine should have all solid food waste and scraps removed. It is recommended that ware also be sprayed down before being placed in the dishwasher.

Place cups and glasses upside-down in racks so they don't hold water during the cycle. Presoak flatware in warm water to assist in removing food. Load plates and saucers in the same direction, with the food surface facing the unload end of the machine.

WASHING A RACK OF WARE

On the I-E-LTH, choose the Normal, Medium, or Heavy cycle before opening the door.

To wash a rack, open the door completely (avoid hot water dripping from the doors) and slide the rack into the unit. Close the doors and the unit will start automatically. Once the cycle is completed, open the door (again careful of the dripping hot water) and remove the rack of clean ware. Replace with a rack of soiled ware and close the doors. The process then repeats itself.

OPERATIONAL INSPECTION

Based upon usage, the pan strainer might become clogged with soil and debris as the workday progresses. Operators should regularly inspect the pan strainer to ensure it has not become clogged. If the strainer becomes clogged, it will reduce the washing capability of the machine. Instruct operators to clean out the pan strainer at regular intervals or as required by workload.

SHUTDOWN & CLEANING

1. Turn machine off by flipping the “OFF/ON/FILL” switch to the “OFF” position.



2. Open the door.



3. Remove the drain stopper and allow tub to drain.



WARNING! Wash tank water could be hot.

4. Remove the sump strainer and pan strainer.

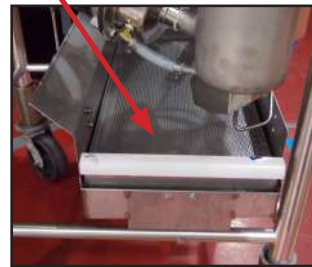

5. Use a hand-scraper to scrape foodsoil into a trash basket.



6. Rinse and replace.
7. Unscrew the wash/rinse arms from their manifolds.



**SHUTDOWN &
CLEANING**

8. Verify the nozzles and arms are free from obstruction. If clogged, remove end-caps, clean nozzles with a brush, and flush with fresh water.



9. Replace end-caps and ensure they have been tightened.

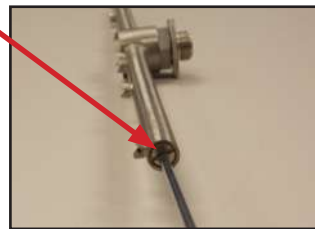

10. Spray or wipe out interior of machine.
11. Replace wash/rinse arms.



12. Ensure sump strainer and scrap screen are clean and securely in place.

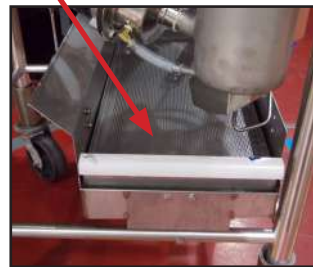

13. Use stainless steel polish to clean and protect the outside of the dishwasher.

DELIMING

1. Follow Filling the Wash Tub section.
2. Add deliming solution per chemical supplier's instructions.
3. Close the door.
4. Flip the NORMAL/DELIME switch on the back of the control box to DELIME.



5. Run machine the period of time recommended by chemical supplier.
6. Wait five minutes, then inspect the inside of the machine. If the machine is not delimed, run again.
7. Flip the NORMAL/DELIME switch to NORMAL.
8. Run two cycles to remove residual deliming solution.
9. Drain and re-fill the machine.



CAUTION! *This equipment is not recommended for use with deionized water or other aggressive fluids. Use of deionized water or other aggressive fluids will result in corrosion and failure of materials and components. Use of deionized water or other aggressive fluids will void the manufacturer's warranty.*

**PREVENTATIVE
MAINTENANCE**

The manufacturer highly recommends that any maintenance and repairs not specifically discussed in this manual be performed only by QUALIFIED SERVICE PERSONNEL. Performing maintenance on your dishmachine may void your warranty, lead to larger problems, or even cause harm to the operator. So if you have a question or concern, do not hesitate to contact a QUALIFIED SERVICE AGENCY.

By following the operating and cleaning instructions in this manual, you should get the most efficient results from your machine. As a reminder, here are some steps to take to ensure that you are using the dishmachine the way it was designed to work:



1. Ensure that the water temperatures match those listed on the machine data plate. There can be a variety of reasons why your water temperature could be too low.
2. Ensure that all strainers are clean and securely in place before operating the machine. When cleaning out strainers, do NOT beat them on waste cans. Wipe out strainers with a rag and rinse under a faucet if necessary. Use a toothpick to dislodge any stubborn debris.
3. Ensure that all wash/rinse arms are secure in the machine before operating.
4. Ensure that the drain stopper is in position before operating.
5. Remove as much soil from ware as possible before loading into racks.
6. Do not overfill racks.
7. Ensure that glasses are placed upside-down in the rack.
8. Ensure that all chemicals being injected into machine have been verified as being at the correct concentrations.
9. Clean out the machine at the end of every workday per the Shutdown and Cleaning section of this manual.
10. Follow all safety procedures, whether listed in this manual or put forth by local, state, or national codes/regulations.

PROBLEM	POSSIBLE CAUSE	REMEDY
Dishmachine will not run, no voltage at wash relay terminals L1 and T1.	<ol style="list-style-type: none"> 1. Service disconnect switch off or faulty. 2. Branch circuit breaker tripped/fuse blown. 3. Loose or broken connection to dishmachine. 	<ol style="list-style-type: none"> 1. Turn disconnect on. 2. Reset or replace. 3. Tighten or replace connections.
Machine will not run in "ON" position or in Delime mode.	<ol style="list-style-type: none"> 1. Door switch is defective. 2. Faulty OFF/ON/FILL switch. 3. Faulty NORMAL/DELIME switch. 	<ol style="list-style-type: none"> 1. With door open, check for voltage between ORANGE/WHITE door switch and neutral. If 120 V, replace the door switch. 2. With switch ON, check voltage between BLACK and WHITE/BLACK wires to switch. Replace the switch if 120 V. 3. In the NORMAL position, check the voltage between WHITE/BLACK and WHITE/RED wires to switch. If 120 V, replace the switch.
Machine fills continuously even with no power applied to the machine.	Water inlet solenoid valve allowing water into machine.	<ol style="list-style-type: none"> 1. Check water pressure during fill, pressure must be 15 PSI. 2. Repair or replace water inlet solenoid valve.
Dishmachine runs continuously in the wash cycle.	<ol style="list-style-type: none"> 1. Machine is in Delime mode. 2. Possible issue with CAM timer. 	<ol style="list-style-type: none"> 1. Flip NORMAL/DELIME switch to NORMAL mode. 2. Contact the manufacturer.
Dishmachine will not hold water.	<ol style="list-style-type: none"> 1. Faulty drain ball. 2. Obstructed drain hole. 3. Drain linkage is binding. 	<ol style="list-style-type: none"> 1. Replace drain ball. 2. Clear obstruction from drain. 3. Repair damaged drain mechanism parts.
Dishmachine will not fill, other functions work.	<ol style="list-style-type: none"> 1. Y-strainer clogged. 2. Incoming water to unit is turned off. 3. Faulty OFF/ON/FILL switch. 4. Faulty solenoid coil. 	<ol style="list-style-type: none"> 1. Clean strainer screen. 2. Turn on water to the machine. 3. Depress switch, measure between BLACK and WHITE/GREEN wires. If 120 V, replace switch. 4. If coil has voltage but no continuity, replace solenoid.

PROBLEM	POSSIBLE CAUSE	REMEDY
Dishmachine fills slowly and/or the rinse is weak.	<ol style="list-style-type: none"> 1. Clogged or obstructed rinse arms. 2. Low incoming water pressure. 3. Y-strainer is clogged. 	<ol style="list-style-type: none"> 1. Remove and clean the rinse arms. 2. Adjust the water pressure regulator to ensure that there is 15 PSI water flow pressure. 3. Clean out the Y-strainer.
Doors will not close completely.	<ol style="list-style-type: none"> 1. Improper spring tension. 2. Obstruction in door channel. 	<ol style="list-style-type: none"> 1. Adjust spring tension as required by loosening (not removing) spring bolt nuts and adjusting the tension. Tighten nuts when done. 2. Remove the obstruction.
Water leaks at wash pump.	<ol style="list-style-type: none"> 1. Wash pump seal is defective. 2. Petcock or pump drain leaking. 	<ol style="list-style-type: none"> 1. Replace wash pump seal. 2. Close shut or tighten.
Ware is not coming clean.	<ol style="list-style-type: none"> 1. Machine temperatures are not up to the minimum requirements. 2. No detergent/too much detergent. 	<ol style="list-style-type: none"> 1. Verify that incoming water temperature meets requirements listed on the machine data plate. 2. Adjust detergent concentration as required for the amount of water held by the machine. (It is recommended the chemical supplier be contacted before making any changes.)

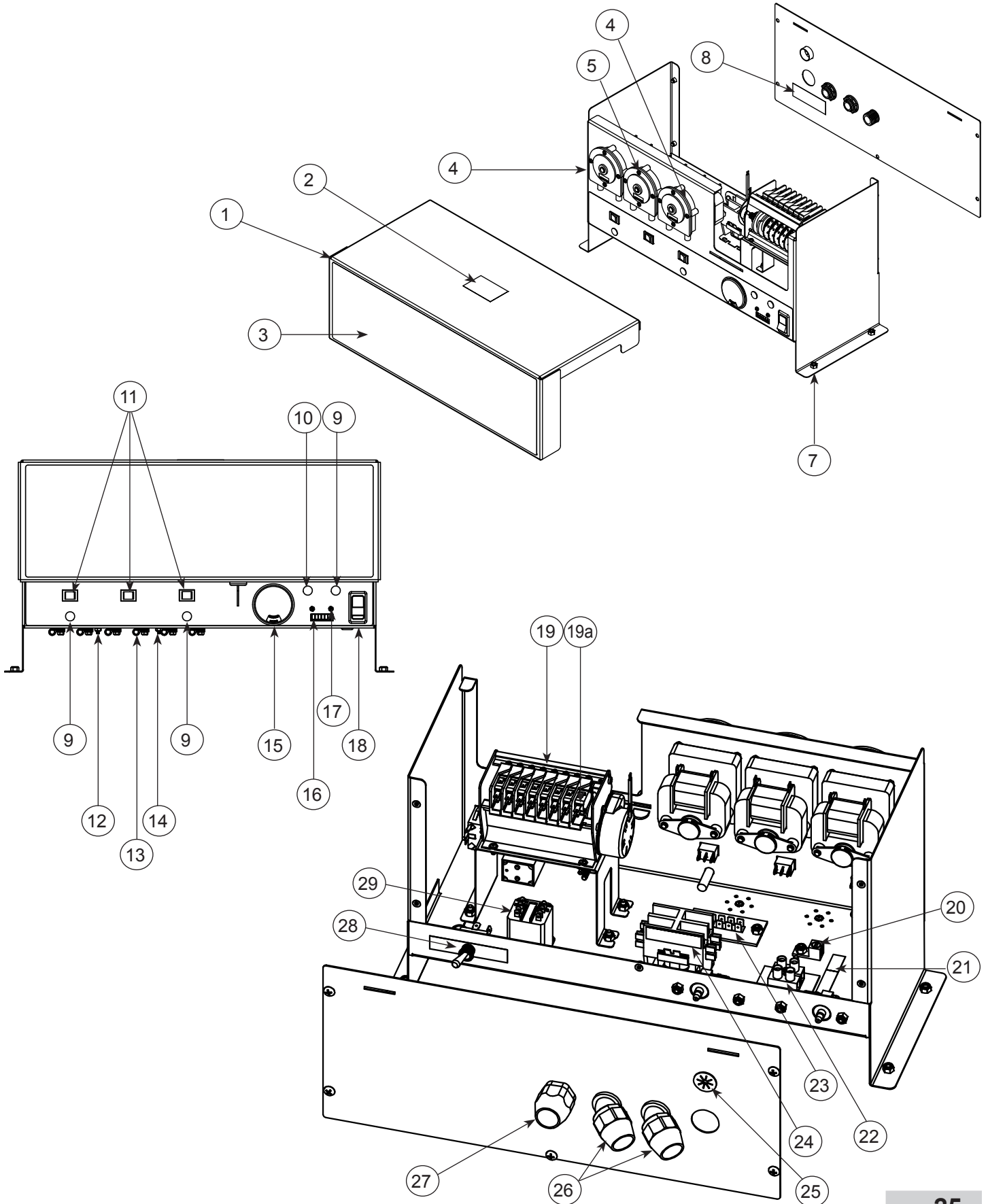

ITEM	QTY	DESCRIPTION	PART NUMBER
1	1	Control Box Top	05700-003-81-49
2	1	Decal, Warning–Disconnect Power	09905-004-08-16
3	1	Upper Decal	09905-004-11-13
4	2	Chemical Feeder Pump Assembly, 36 RPM (208 V Units)	05700-003-78-74
		Chemical Feeder Pump Assembly, 36 RPM (115 V Units)	05700-003-25-02
5	1	Chemical Feeder Pump Assembly, 14 RPM (208 V Units)	05700-003-31-86
		Chemical Feeder Pump Assembly, 14 RPM (115 V Units)	05700-003-25-03
7	18	Lock Nut, 10-24 SS Hex w/Nylon Insert	05310-373-01-00
8	1	Decal, Copper Conductors	09905-011-47-35
9	3	Light, Red	05945-504-07-18
10	1	Light, Green	05954-504-08-18
11	3	Switch, Prime	05930-011-49-54
12	6	Screw, 6-32 x 3/8" w/Washer	05305-002-25-91
13	6	P-clamp 1/4" ID	05975-002-61-42
14	11	Lock Nut, 6-32 Hex w/Nylon Insert	05310-373-03-00
15	1	Temperature Gauge	06685-004-31-45
16	1	Cycle Counter, 115 V	05990-111-35-38
17	2	Screw, 4-40 x 1/4" Phillips Pan Head w/Washer	05305-002-32-38
18	1	Switch, Power	05930-111-38-79
19	1	Timer	05945-004-11-78
19a	8	Microswitch, Timer	05930-011-65-81
20	1	Lug, Ground	05940-200-76-00
21	1	Decal, Power Connection	09905-011-47-64
22	1	Terminal Block	05940-500-09-61
23	1	Terminal Board	05940-021-94-85
24	1	Contact, 115 V, 30 A	05945-002-74-20
25	1	Bushing, Heyco Split	05975-200-40-00
26	2	Fitting, 1/2", 45-degree, Plastic	05975-011-45-23
27	1	Fitting, 1/2", Plastic	05975-011-45-13
28	1	Switch, Delime	05930-301-21-18
29	1	Relay, Pole 115 V	05945-111-35-19
	1	Relay, Pole 208 V	05945-111-47-51
	1	Lock, Control Box (Not Shown)	05340-102-01-00

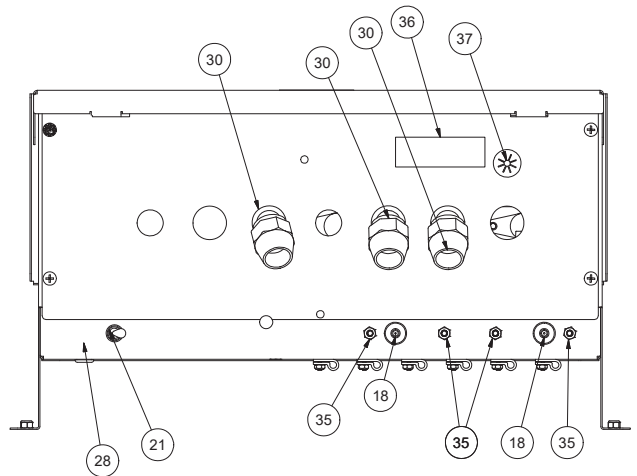
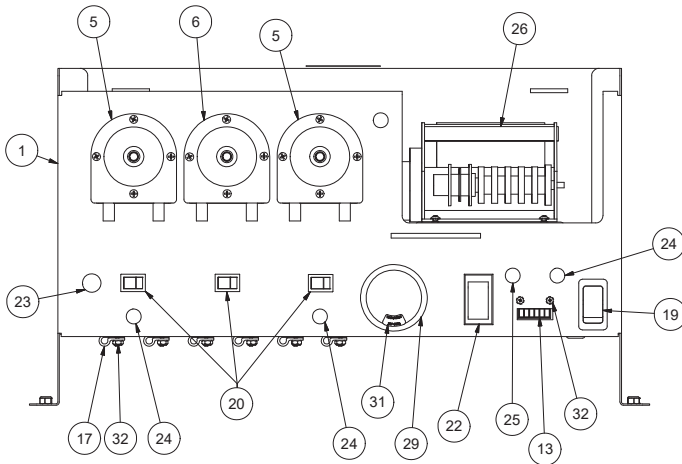
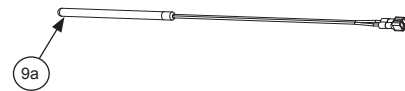
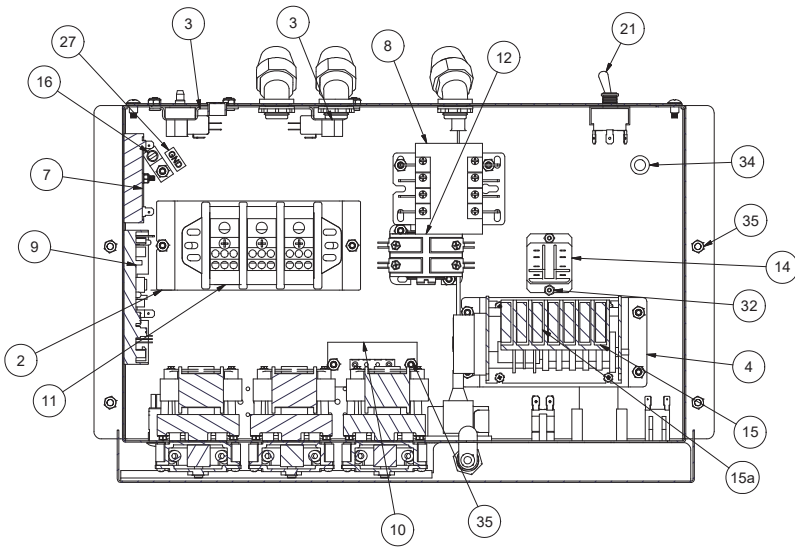

ITEM	QTY	DESCRIPTION	PART NUMBER
		I-E-LTH Control Box Complete Assembly	05700-004-49-01
1	1	Box, Control Assembly	05700-004-49-02
2	1	Bracket, Terminal Block	05700-004-51-59
3	2	Bracket, Pressure Switch	05700-004-08-99
4	1	Bracket, Timer Mounting	05700-004-08-77
5	2	Chemical Feeder Pump Assembly, 36 RPM	05700-003-78-74
6	1	Chemical Feeder Pump Assembly, 14 RPM	05700-003-31-86
7	1	Timer, Wash Cycle Delay	05945-002-13-78

ITEM	QTY	DESCRIPTION	PART NUMBER
8	1	Contactora, 30 A	05945-004-43-74
9	1	Thermostat, Elan Electric (Dual)	06685-004-17-27
9a	1	Probe, Thermistor 4"	06685-004-17-26
10	1	Terminal Board	05940-021-94-85
11	1	Terminal Block, 3-Pole	05940-011-48-27
12	1	Contactora, 30 A	05945-002-74-20
13	1	Counter, Plastic	05990-111-47-42
14	1	Relay, Top Mount	05945-111-47-51
15	1	Timer	05945-111-48-25
15a	8	Microswitch, Timer	05930-011-65-81
16	1	Lug, Ground	05940-200-76-00
17	6	P-clamp, 1/4" ID	05975-002-61-42
18	2	Switch, Pressure	06685-003-36-13
19	1	Switch, On/Off/Fill	05930-111-38-79
20	3	Switch, Chemical Prime	05930-011-49-54
21	1	Switch, Normal/Delime	05930-301-21-18
22	1	Switch, Cycle	05930-301-49-00
23	1	Light, Amber	05945-111-44-44
24	3	Light, Red	05945-504-07-18
25	1	Light, Green	05945-504-08-18
26	1	Decal, Timer Cam Operation	09905-011-37-21
27	1	Decal, Ground	09905-011-86-86
28	1	Decal, Normal/Delime	09905-011-34-96
29	1	Temperature Gauge	06685-004-31-46
30	3	Fitting, 1/2", 45-degree Plastic	05975-011-45-23
31	1	Decal, Wash/Rinse	09905-002-82-46
32	14	Locknut, 6-32 Hex with Nylon Insert	05310-373-03-00
33	2	Screw, 4-40 x 1/4" with Washer	05305-002-32-38
34	1	Grommet, 1/2" OD x .38" ID	05325-011-46-73
35	21	Locknut, 10-24 Hex with Nylon Insert	05310-373-01-00
36	1	Decal, Copper Conductors	09905-011-47-35
37	1	Bushing, Split	05975-200-40-00
	1	Lock, Control Box (Not Shown)	05340-102-01-00

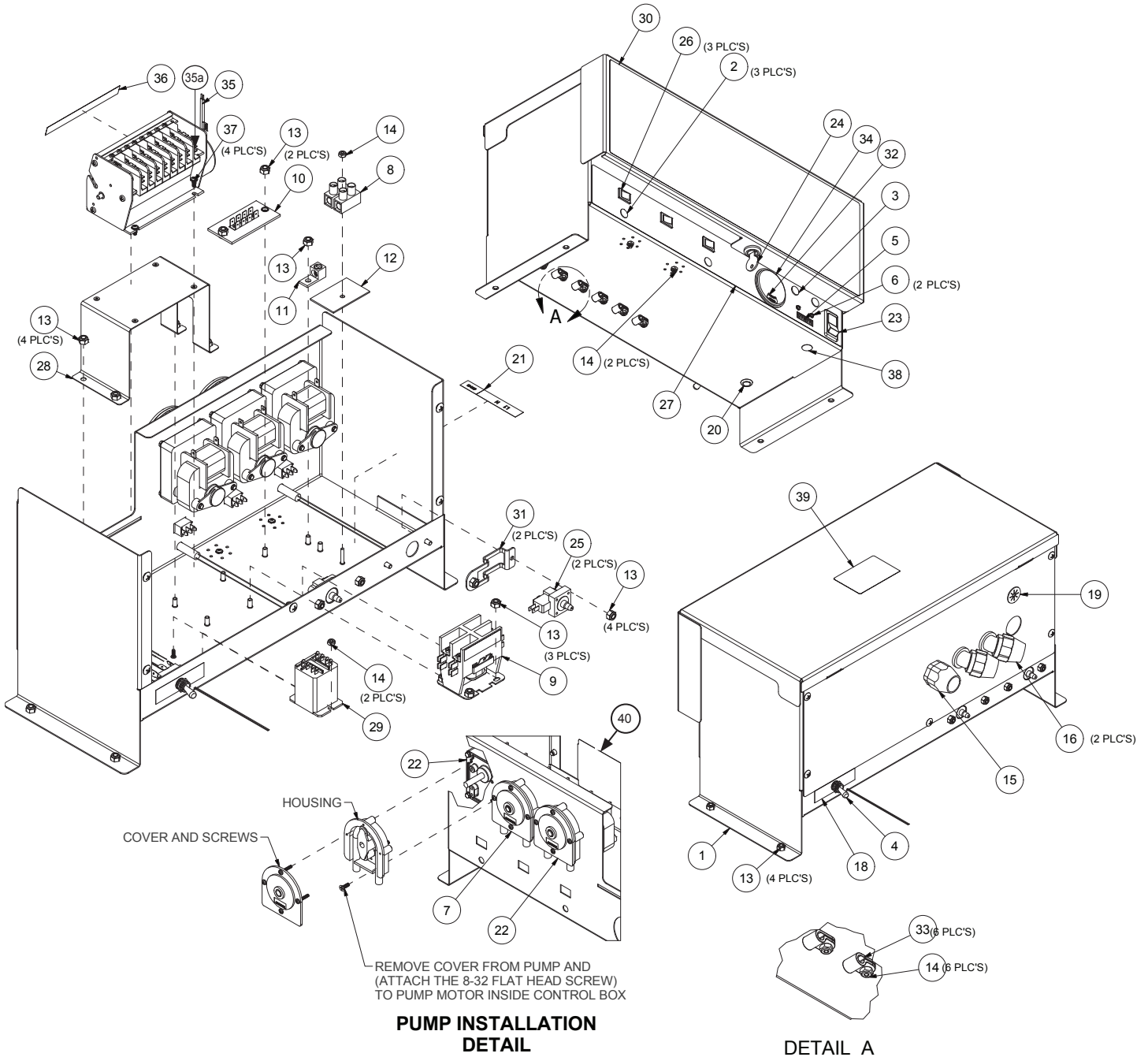

ITEM	QTY	DESCRIPTION	PART NUMBER
		High Hood Control Box Complete Assembly	05700-004-25-41
1	1	Control Box Weldment	05700-003-81-49
2	3	Light, Red	05945-504-07-18
3	1	Light, Green	05945-504-08-18
4	1	Switch, Carling	05930-301-21-18
5	1	Counter, 115 V	05990-111-35-38
	1	Counter, 208 V	05990-111-47-42
6	2	Screw, 4-40 x 1/4" Phillips Pan Head w/Washer	05305-002-32-38
7	1	Chemical Feeder Pump Assembly, 14 RPM (208 V Units)	05700-003-31-86
		Chemical Feeder Pump Assembly, 14 RPM (115 V Units)	05700-003-25-03
8	1	Block, Altech Terminal	05940-500-09-61
9	1	Contactor, 115 V	05945-109-05-69
	1	Contactor, 208 V	05945-002-74-20
10	1	Terminal Board	05940-021-94-85
11	1	Lug, Panduit Ground	05940-200-76-00
12	1	Spacer, Terminal Block	05700-011-40-05
13	18	Nut, Lock 10-24 SS Hex w/Nylon Insert	05310-373-01-00
14	11	Nut, Lock 6-32 Hex w/Nylon Insert	05310-373-03-00
15	1	Fitting, T&B 1/2" Plastic	05975-011-45-13
16	2	Fitting, T&B 1/2" 45-degree Plastic	05975-011-45-23
17	1	Decal, Copper Conductors	09905-011-47-35
18	1	Decal, Delime/Normal	09905-011-34-96
19	1	Grommet, 7/8" Split Helco	05975-200-40-00
20	1	Grommet, 1/2" OD x 0.38" ID	05325-011-46-73
21	1	Decal, Power Connection	09905-011-47-64
22	2	Chemical Feeder Pump Assembly, 36 RPM (208 V Units)	05700-003-78-74
		Chemical Feeder Pump Assembly, 36 RPM (115 V Units)	05700-003-25-02
23	1	Switch, Carling	05930-111-38-79
24	1	Lock, Control Box	05340-102-01-00
25	2	Switch, Pressure	06685-003-36-13
26	3	Switch, Prime	05930-011-49-54
27	1	Decal, Lower Control	09905-004-21-08
28	1	Bracket, Timer Mounting	05700-004-08-77
29	1	Relay, Pole 115 V	05945-111-35-19
	1	Relay, Pole 208 V	05945-111-47-51

ITEM	QTY	DESCRIPTION	PART NUMBER
30	1	Upper Decal	09905-004-11-13
31	2	Bracket, Pressure Switch	05700-004-08-99
32	1	Decal, Wash/Rinse	09905-002-82-46
33	6	P-clamp 1/4" ID	05975-002-61-42
34	1	Temperature Gauge	06685-111-68-49
35	1	Timer	05945-004-11-78
35a	8	Microswitch, Timer	05930-011-65-81
36	1	Decal, Timer Cam Operation	09905-004-37-27
37	6	Screw, 6-32 x 3/8" SEMS w/Ext Wash	05305-002-25-91
38	1	Plug, 2643 1/3" Heyco Hole	04730-011-60-22
39	1	Label, Disconnect Power Warning	09905-004-08-16
40	1	Tag, Power Warning 115 V	09905-011-46-87

NOTICE For complete Chemical Feeder Pump Assembly part numbers, see the Control Box pages.

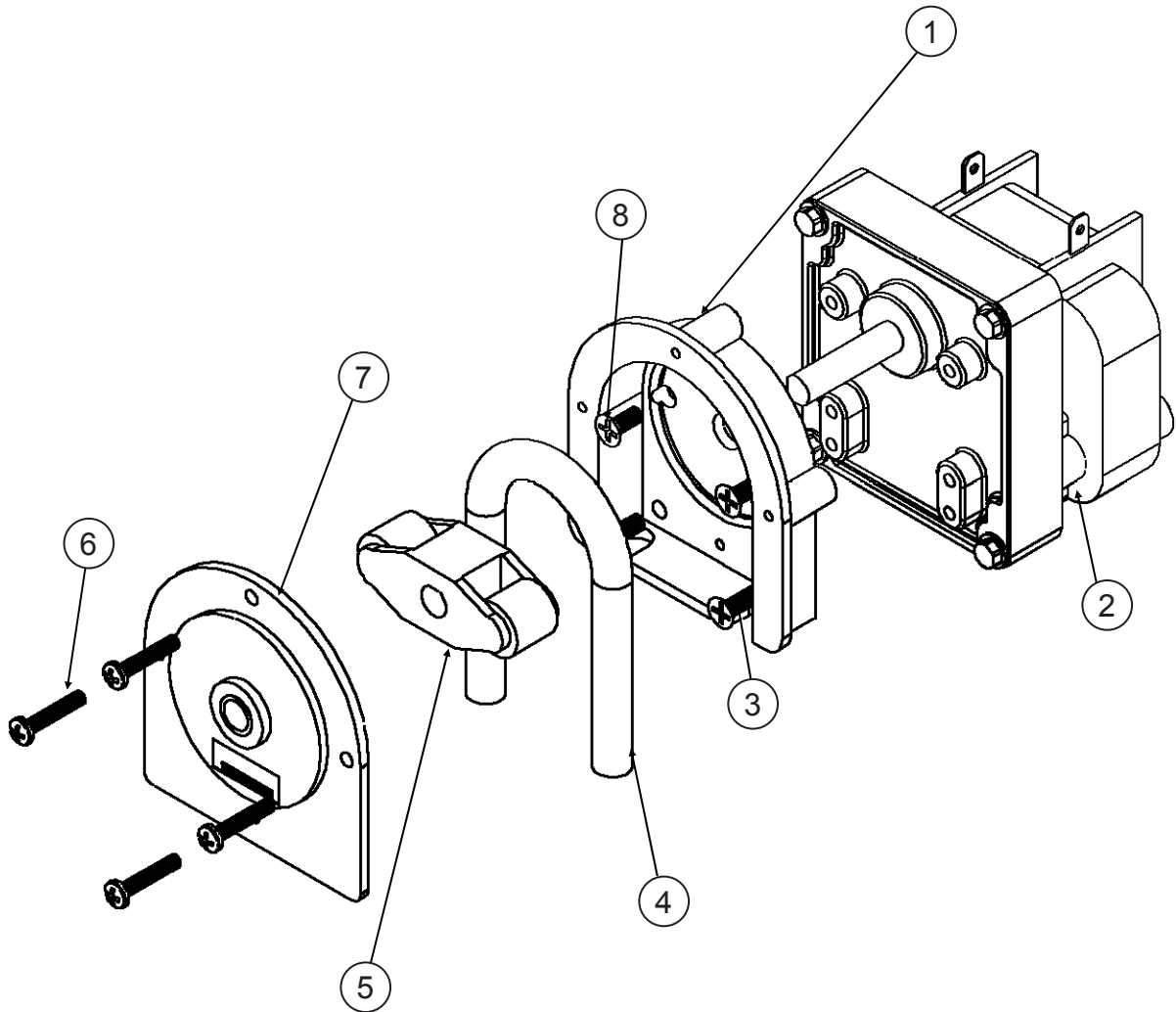

If using Tygoprene Tubing:

Roller, White

04320-002-82-28

Roller, Black

04320-111-65-27

ITEM	QTY	DESCRIPTION	PART NUMBER
1	1	Rear Housing	04320-111-37-09
2	1	Motor, 14 RPM 115 V Rinse-aid Feeder Pump	04320-111-35-13
		Motor, 14 RPM 208/230 V, Rinse-aid Feeder Pump	04320-111-47-46
	1	Motor, 36 RPM 115 V, Detergent/Sanitizer Feeder Pump	04320-111-35-14
		Motor, 36 RPM 208/230 V, Detergent/Sanitizer Feeder Pump	04320-111-47-47
3	2	Screw, 8-32 x 1/2" Phillips Flat Head	05305-011-37-06
4	1	Tube, 3/16" x 8" Clear Tygoprene	05700-003-22-89
5	1	Roller, White	04320-002-82-28
6	4	Screw, 6-32 x 3/4" Phillips Pan Head	05305-011-37-05
7	1	Front Housing	04320-111-37-08
8	2	Screw, 8-32 x 3/8" Flat Head	05305-011-37-07

NOTICE Before ordering plumbing assembly or plumbing parts, see the note on the next page.

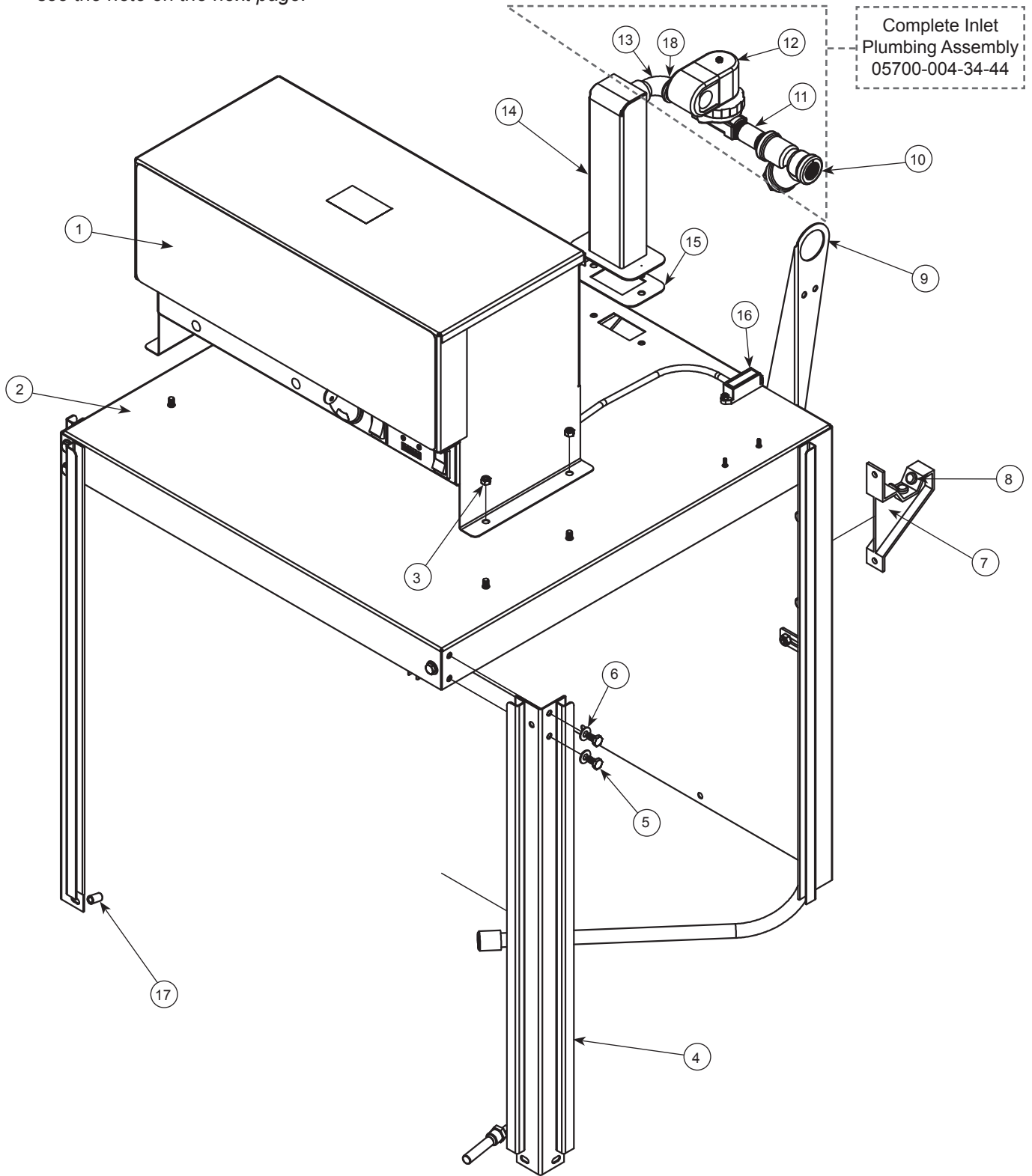

ITEM	QTY	DESCRIPTION	PART NUMBER
1	1	Control Box Assembly, 115 V Control Box Assembly, 208 V	05700-004-01-65 05700-004-16-66
2	1	Hood, Weldment	05700-004-08-68
3	10	Locknut, 1/4-20 with Nylon Insert	05310-374-01-00
4	2	Hood Support	05700-002-78-99
5	6	Bolt, 1/4-20 x 1/2"	05305-274-02-00
6	12	Washer, SS 1/4"	05311-174-01-00
7	2	Bracket, Cantilever Support	09515-003-15-64
8	6	Wear Button	05700-011-88-01
9	1	Bracket, Plumbing Support	05700-003-24-25
10	1	Y-Strainer, 3/4" NPT Brass	04730-717-02-06
11	1	Nipple, 3/4" x 3" Brass	04730-011-38-29
12	1	Solenoid Valve, 3/4", 115 V Solenoid Valve, 3/4", 208 V	04810-100-53-00 04810-100-03-18
13	1	Elbow, 3/4" Street Brass	04730-206-04-34
14	1	Air-gap	05700-004-34-42
15	1	Gasket, Air-gap	05330-002-14-48
16	1	Reed Switch	05930-002-36-80
17	4	Spacer, Sleeve Hood	05700-003-55-15
18	1	Nipple, 3/4" x 1 3/8" Brass	04730-207-34-00

NOTICE Machines with serial numbers before 17C331529 have 1/2" plumbing. Click [here](#) to open the manual which shows the 1/2" plumbing.

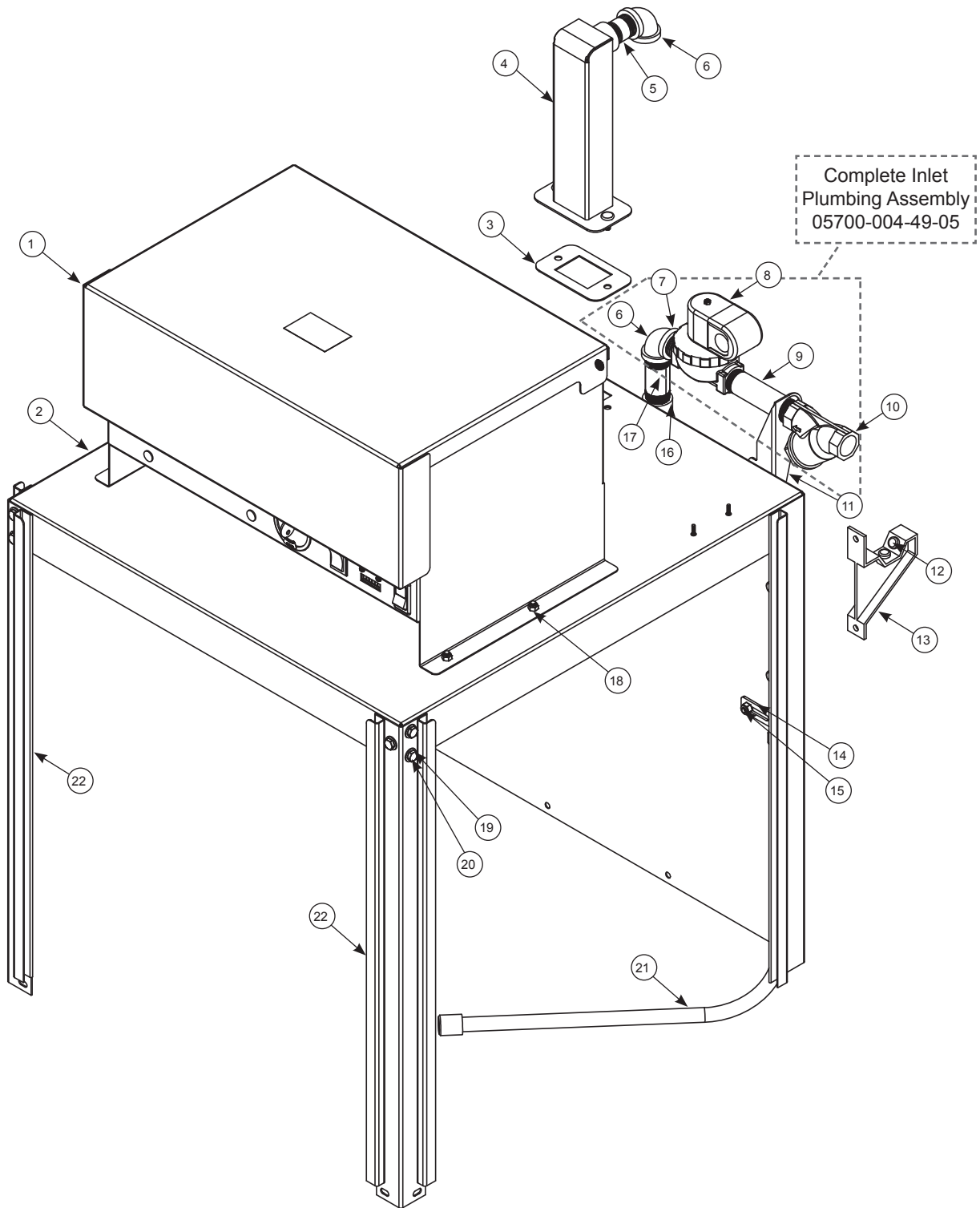

ITEM	QTY	DESCRIPTION	PART NUMBER
1	1	Control Box Assembly, I-E-LTH	05700-004-49-01
2	1	Hood, Weldment	05700-004-08-68
3	1	Gasket, Air-gap	05330-002-14-48
4	1	Air-gap	05700-004-34-42
5	1	Nipple, 3/4" x 2" Brass	04730-207-46-00
6	2	Elbow, 3/4", 90-degree Brass	04730-206-13-00
7	1	Nipple, 3/4" x 1 3/8" Brass	04730-207-34-00
8	1	Solenoid Valve, 3/4", 208/230 V	04810-100-03-18
9	1	Nipple, 3/4" x 4 1/2" Brass	04730-004-04-53
10	1	Y-Strainer, 3/4" NPT Brass	04730-717-02-06
11	1	Bracket, Plumbing Support	05700-004-48-11
12	6	Wear Button	05700-011-88-01
13	2	Bracket, Cantilever Support	09515-003-15-64
14	1	Bracket, Manifold Position Tube	05700-011-34-63
15	1	Locknut, 1/4-20 with Nylon Insert	05310-373-01-00
16	1	Coupling, 3/4"	04730-704-04-00
17	1	Nipple, 3/4" x 3" Brass	04730-011-38-29
18	10	Locknut, 10-24 with Nylon Insert	05310-374-01-00
19	12	Washer, SS 1/4"	05311-174-01-00
20	6	Bolt, 1/4-20 x 1/2"	05305-274-02-00
21	1	Manifold, Wash Feed	05700-003-58-89
22	2	Hood Support	05700-002-78-99

NOTICE Before ordering plumbing assembly or plumbing parts, see the note on the next page.

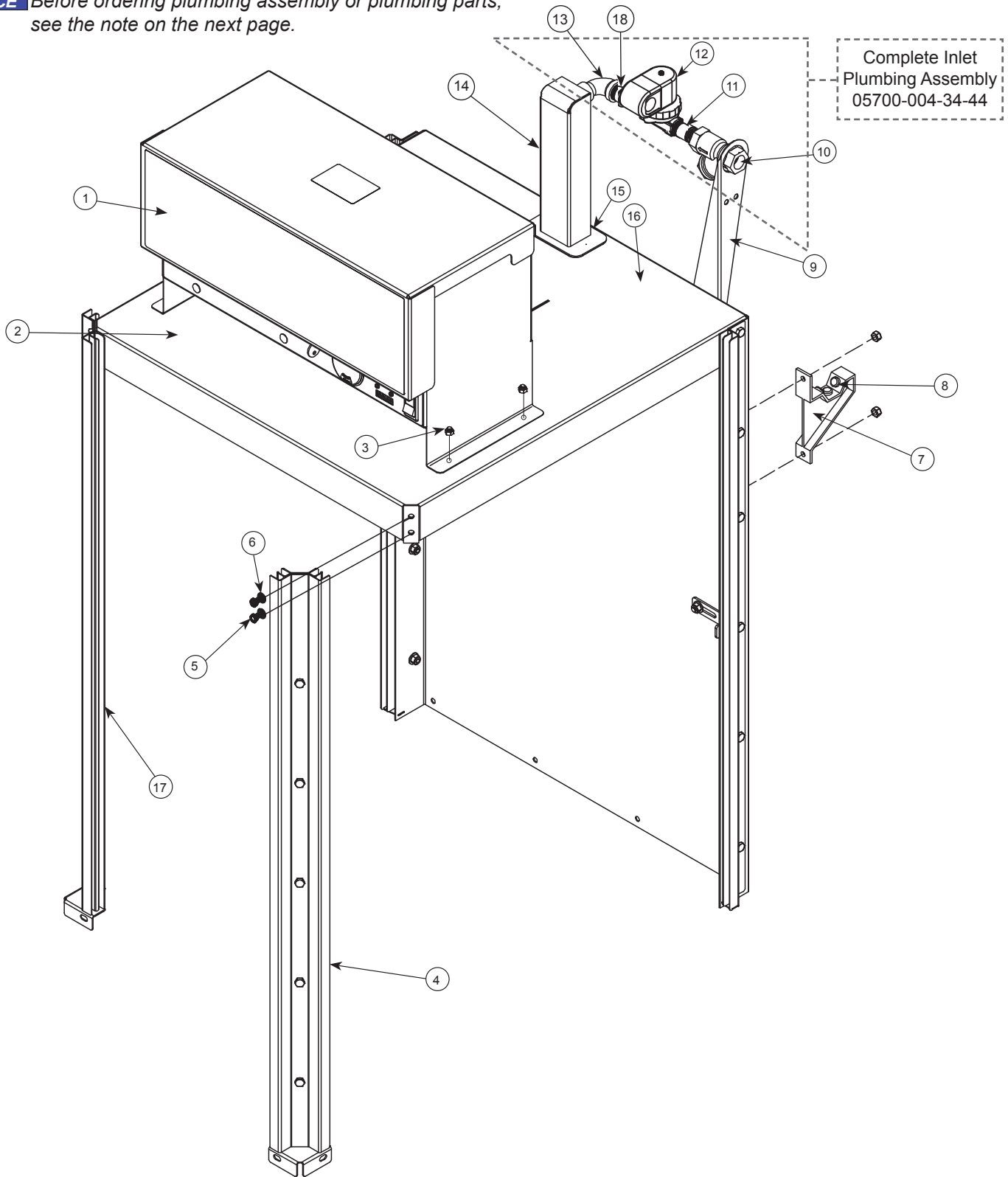

ITEM	QTY	DESCRIPTION	PART NUMBER
1	1	Control Box Assembly, 115 V Control Box Assembly, 208 V	05700-004-25-41 05700-004-30-24
2	1	Hood, Weldment	05700-004-24-96
3	10	Locknut, 1/4-20 with Nylon Insert	05310-374-01-00
4	2	Hood Support	05700-004-13-45
5	6	Bolt, 1/4-20 x 1/2"	05305-274-02-00
6	12	Washer, SS 1/4"	05311-174-01-00
7	2	Bracket, Cantilever Support	09515-003-15-64
8	6	Wear Button	05700-011-88-01
9	1	Bracket, Plumbing Support	05700-003-24-25
10	1	Y-Strainer, 3/4" NPT Brass	04730-717-02-06
11	1	Nipple, 3/4" x 3" Brass	04730-011-38-29
12	1	Solenoid Valve, 3/4", 115 V Solenoid Valve, 3/4", 208 V	04810-100-53-00 04810-100-03-18
13	1	Elbow, 3/4" Street Brass	04730-206-04-34
14	1	Air-gap	05700-004-34-42
15	1	Gasket, Air-gap	05330-002-14-48
16	1	Reed Switch	05930-002-36-80
17	4	Spacer, Sleeve Hood	05700-003-55-15
18	1	Nipple, 3/4" x 1 3/8" Brass	04730-207-34-00

NOTICE Machines with serial numbers before 17C331529 have 1/2" plumbing. Click [here](#) to open the manual which shows the 1/2" plumbing.

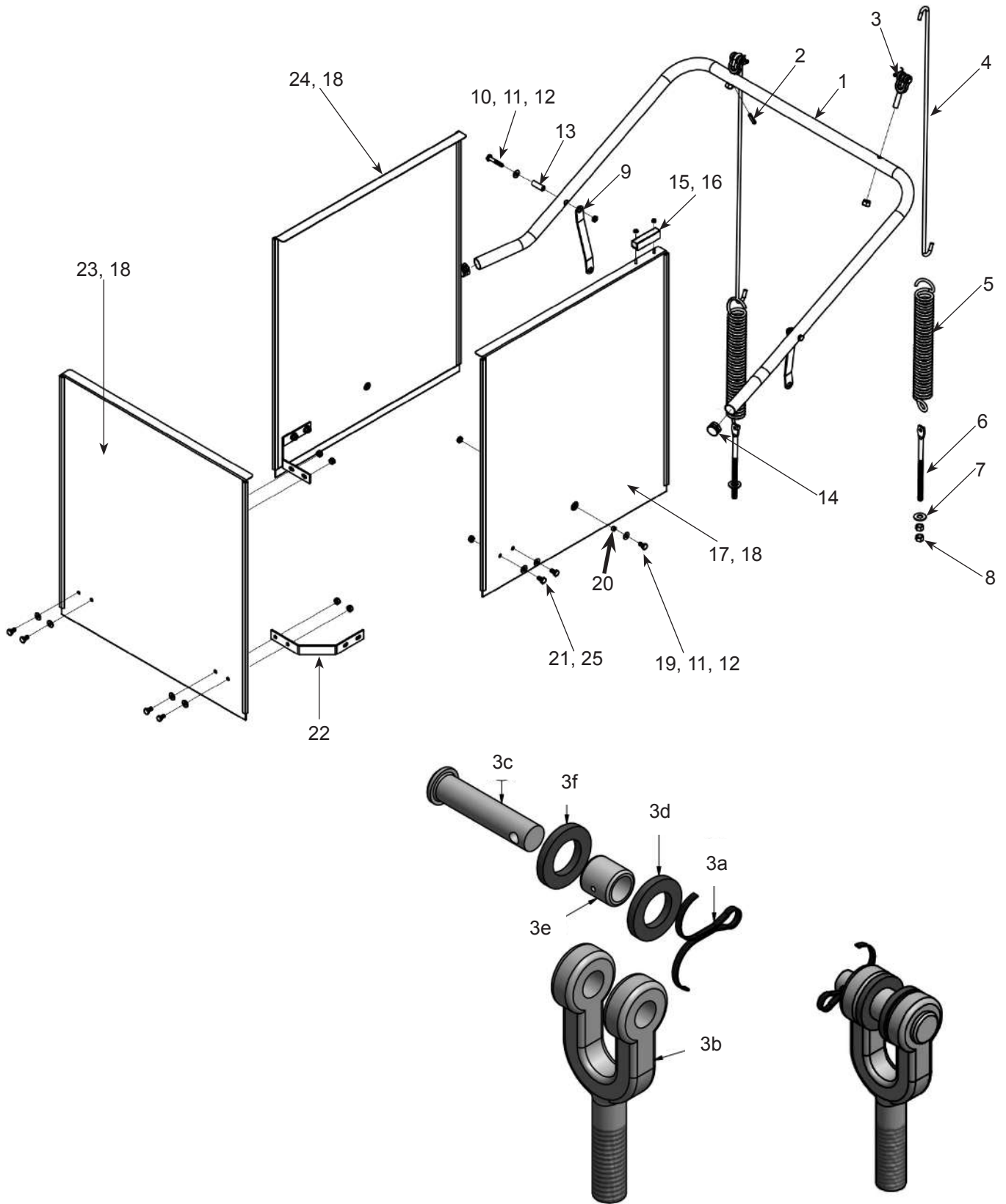

ITEM	QTY	DESCRIPTION	PART NUMBER
1	1	Arm, Cantilever	05700-031-50-67
2	2	Spring Pin, 1/4" Dia. x 1 1/8"	05315-407-06-00
3	2	Yoke Assembly	05700-000-75-77
3a	1	Cotter Pin	05315-207-01-00
3b	1	Yoke	05700-000-75-78
3c	1	Clevis Pin	05315-700-01-00
3d	2	Nylon Washer	05311-369-03-00
3e	1	Bushing	03120-100-03-00
3f	2	Lock Nut, 3/8-16 SS (Not Shown)	05310-256-04-00
4	2	Rod, Spring Universal	05700-003-67-39
5	2	Spring, Cantilever	05340-109-02-00
6	2	Bolt, Hanger Eye 3/8-16	05306-956-05-00
7	2	Washer, 3/8" ID x 7/8" OD	05311-176-02-00
8	4	Nut, Hex 3/8-16 SS	05310-276-01-00
9	2	Cantilever Arm Connector	05700-011-90-99
10	2	Screw, 1/4-20	05305-274-23-00
11	2	Washer, 1/4" ID SS	05311-174-01-00
12	2	Lock Nut, 1/4-20 SS w/Nylon Insert	05310-374-02-00
13	2	Sleeve, Cantilever Arm	05700-000-85-69
14	2	Plug, Cantilever	05340-011-35-00
15	1	Door Magnet	06401-004-07-73
16	2	Lock Nut, 8-32 SS w/Nylon Insert	05310-272-02-00
17	1	Door Assembly, Right Side	05700-004-14-11
18	6	Door Guides	05700-111-33-59
19	10	Bolt, 1/4-20 x 1/2" SS	05305-274-02-00
20	2	Spacer, PB Bolt	05700-000-29-40
21	8	Lock Nut, 1/4-20 w/Nylon Insert	05310-374-01-00
22	2	Bracket, Door Connecting	05700-021-33-39
23	1	Front Door Assembly	05700-002-30-89
24	1	Door Assembly, Left Side	05700-004-14-10

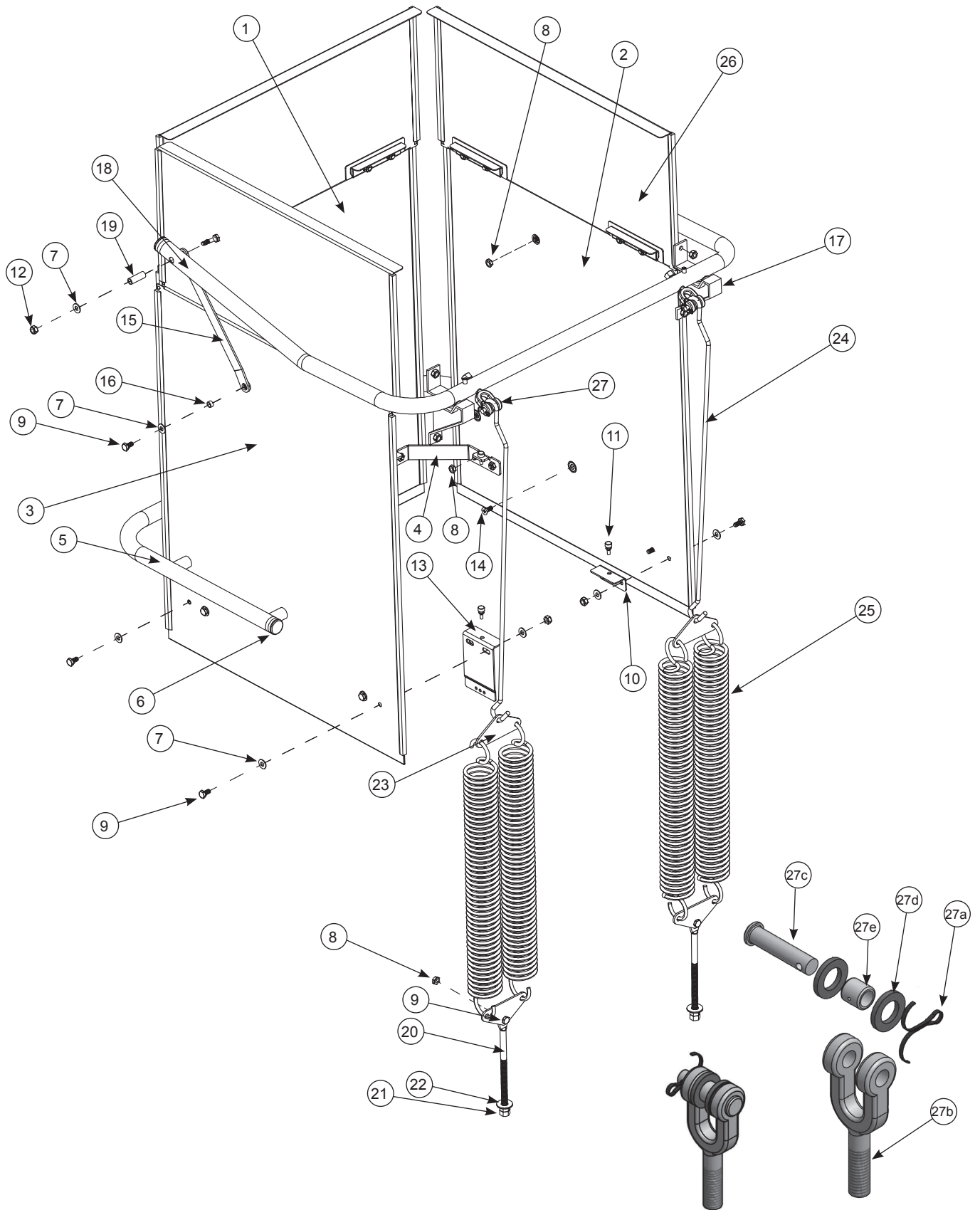

ITEM	QTY	DESCRIPTION	PART NUMBER
1	1	Door, Front Outer	05700-004-14-21
2	1	Door, Left Outer	05700-004-14-19
3	1	Door, Right Outer	05700-004-14-17
4	2	Bracket, Door Connecting	05700-004-14-23
5	1	Handle, Door Front	05700-004-14-30
6	2	Plug, Cantilever	05340-011-35-00
7	22	Washer, 1/4-20 ID	05311-174-01-00
8	12	Locknut, 1/4-20 Low Profile with Nylon Insert	05310-374-02-00
9	16	Bolt, 1/4-20 x 1/2" Long	05305-274-02-00
10	1	Door Stop	05700-002-00-84
11	2	Bumper, HH Door	05700-004-14-25
12	10	Nut, Lock 1/4-20 Hex with Nylon Insert	05310-374-01-00
13	1	Magnet, Door Stop Assembly	05700-002-25-08
14	4	Screw, 1/4-20 x 5/8"	05305-002-20-30
15	2	Connecting Link	05700-021-92-45
16	2	Spacer, PB Bolt	05700-000-29-40
17	2	Cantilever Arm Bracket	05700-003-88-91
18	1	Cantilever Arm	05700-004-14-32
19	2	Sleeve, Cantilever Hang Eye	05700-000-85-69
20	2	Bolt, Cantilever Hang Eye	05306-956-05-00
21	4	Nut, Hex 3/8-16	05310-276-01-00
22	2	Washer, Impeller 3/8"	05311-176-02-00
23	4	Plate, Spring Multiplier	05700-002-00-88
24	2	Spring Link	05700-002-00-91
25	4	Spring, Cantilever Door	05340-111-35-22
26	3	Door Upper	05700-002-01-30
27	2	Yoke Assembly	05700-000-75-77
27a	1	Cotter Pin	05315-207-01-00
27b	1	Yoke	05700-000-75-78
27c	1	Clevis Pin	05315-700-01-00
27d	2	Nylon Washer	05311-369-03-00
27e	1	Bushing	03120-100-03-00
N/A	2	Lock Nut, 3/8-16 SS (Not Shown)	05310-256-04-00
N/A	2	Lower Door Glide (Not Shown)	05700-002-23-64
N/A	2	Upper Door Glide (Not Shown)	05700-002-00-83

Wash Arm Assembly
05700-003-59-35

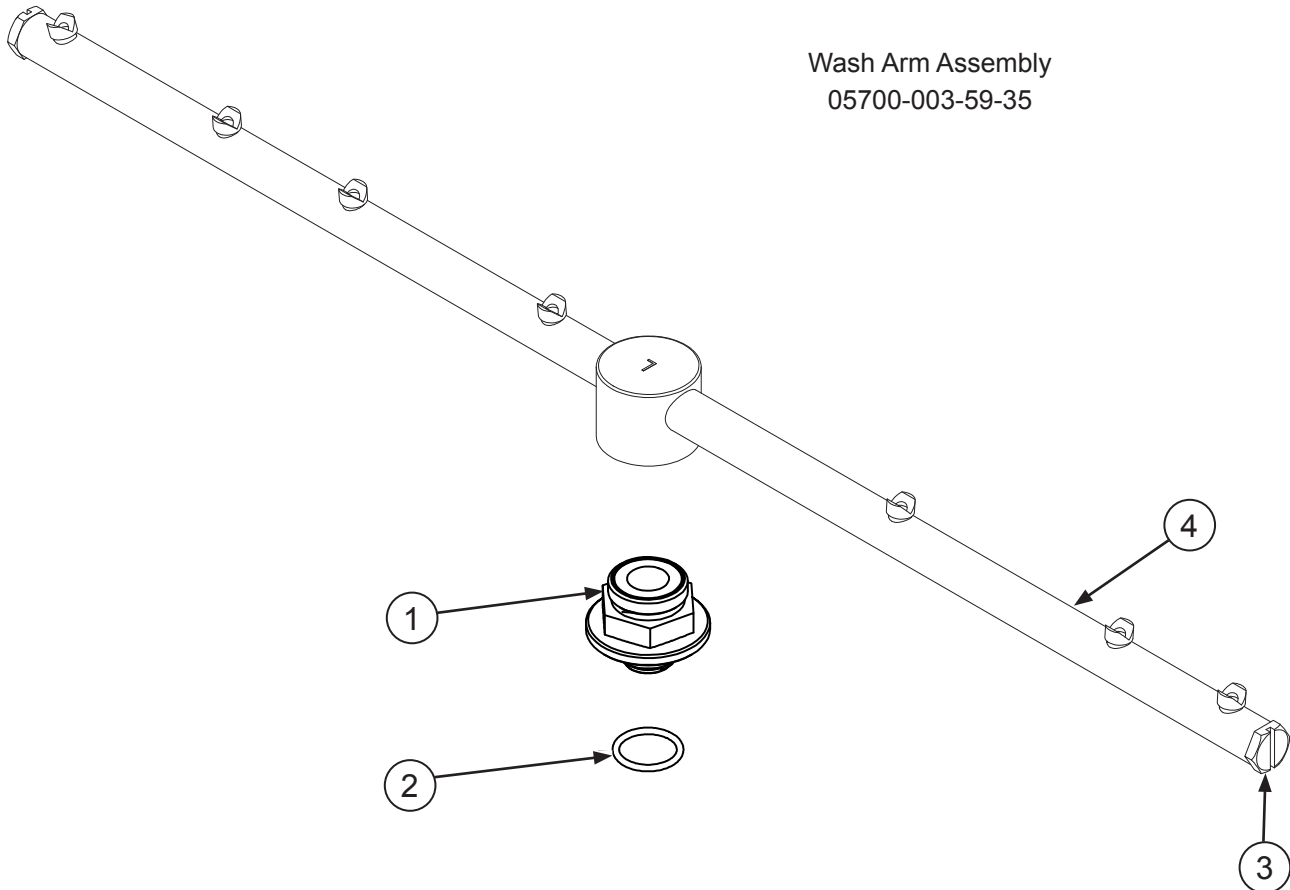

ITEM	QTY	DESCRIPTION	PART NUMBER
1	1	Bearing Assembly	05700-021-35-97
2	1	O-ring, 117-S70 Silicon	05330-002-60-69
3	2	Wash Arm End-cap	05700-011-35-92
4	1	Wash Arm	05700-003-57-70

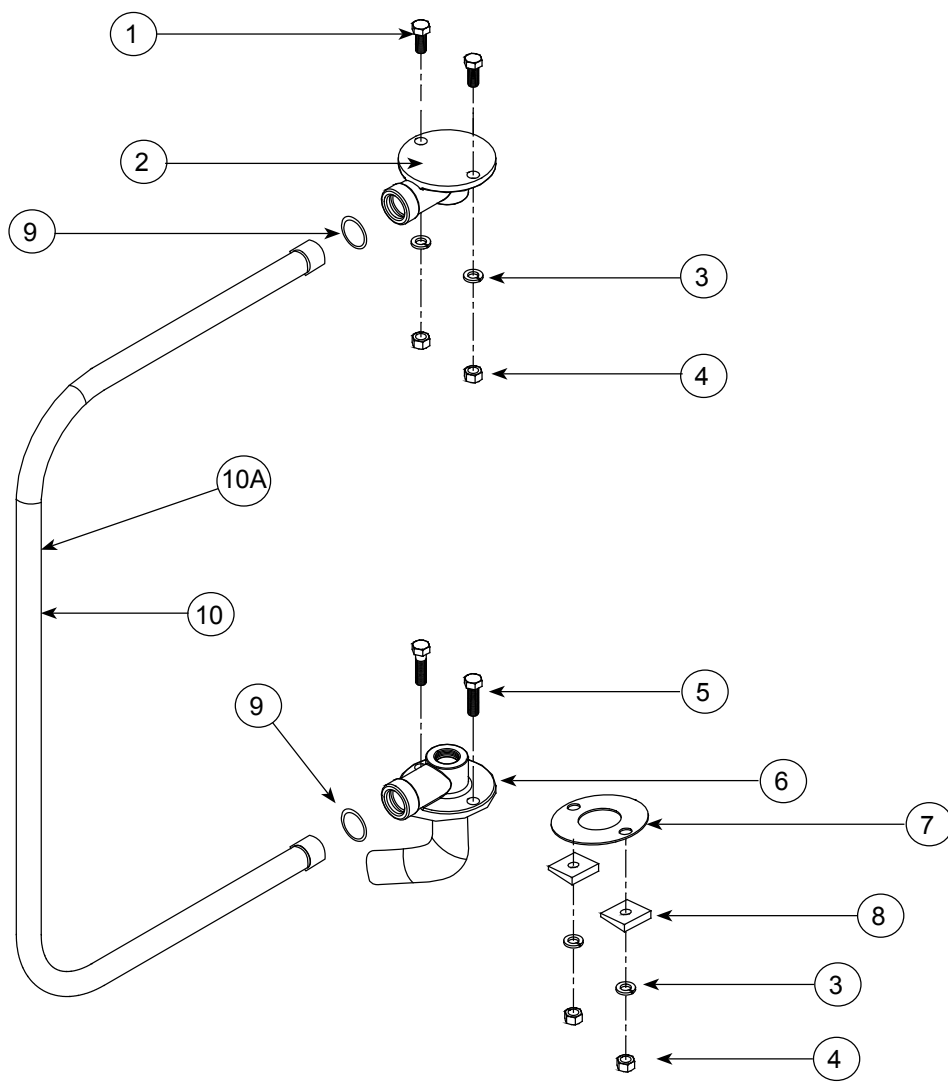

ITEM	QTY	DESCRIPTION	PART NUMBER
1	2	Bolt, 3/8-16 x 3/8" SS	05306-011-36-95
2	1	Casting, Upper Wash Manifold	05700-031-34-82
3	4	3/8" Lockwasher, SS	05311-276-01-00
4	4	3/8" Hex Nut, SS	05310-276-01-00
5	2	Bolt, 3/8-16 x 1 1/4" SS	05305-276-10-00
6	1	Lower Wash Manifold	05700-003-78-40
7	1	Gasket, Wash Manifold	05700-111-35-03
8	2	3/8" Bevel, Square	05311-011-35-36
9	2	O-ring	05330-111-35-15
10	1	Wash Manifold Tube	05700-003-58-89
10a	1	Wash Manifold Tube High Hood (Not Shown)	05700-004-25-71

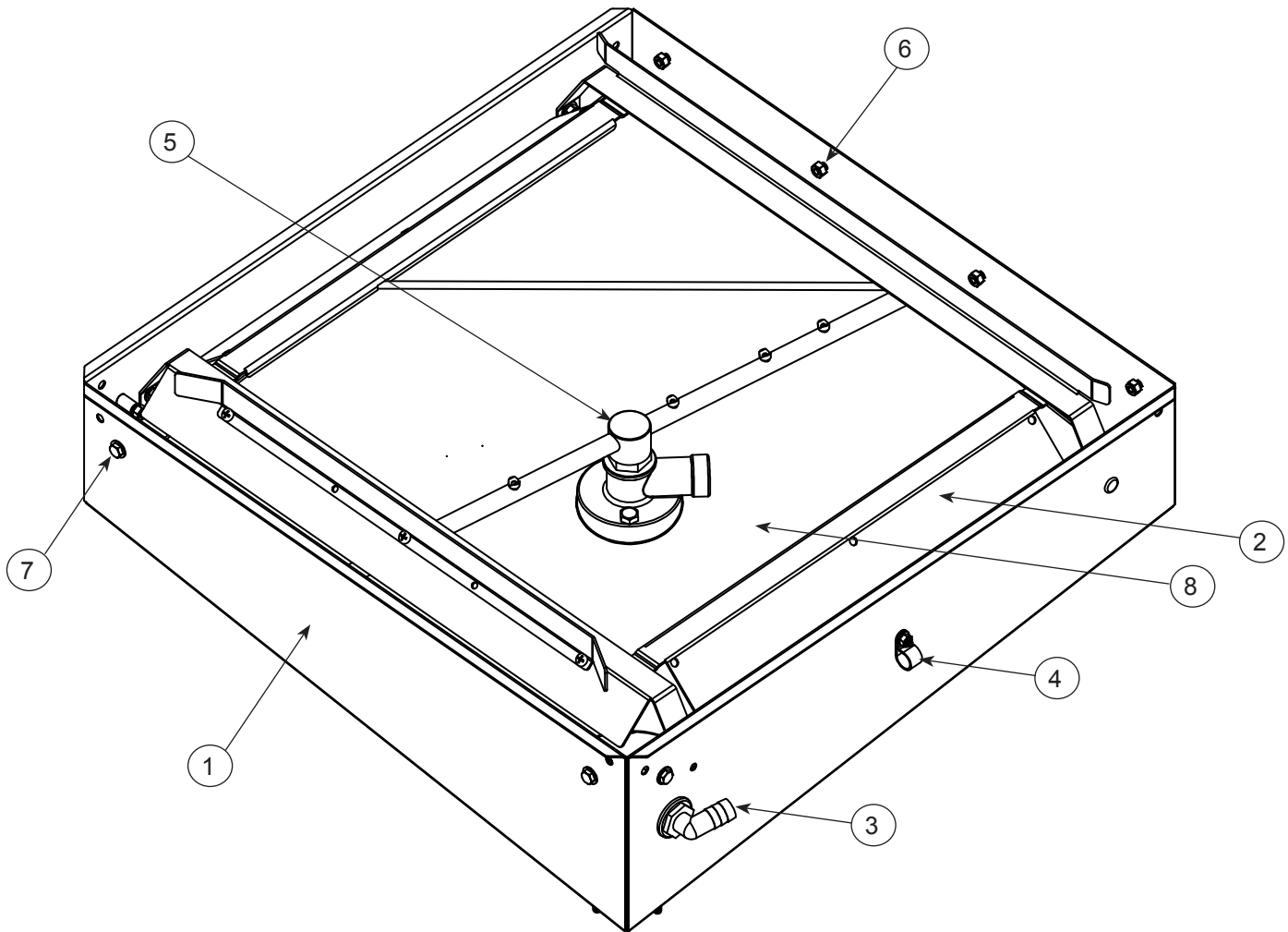

ITEM	QTY	DESCRIPTION	PART NUMBER
1	1	Tub Assembly, I-E/I-E-LTH	05700-003-78-39
	1	Tub Assembly, I-HH	05700-004-27-28
2	1	Rack Guide Assembly	05700-031-36-76
3	1	Bulkhead Fitting, 1/2"	04730-011-45-21
4	1	Clamp, Nylon	04730-011-39-01
	1	Lock Nut, 10-24 SS	05310-373-01-00
5	1	Wash Arm Assembly	05700-003-59-35
6	4	Bolt, 1/4-20 x 1/2" SS	05305-274-02-00
	4	Lock Nut, 1/4-20 SS	05310-374-01-00
7	4	Bolt, 1/4-20 x 1 1/8" SS	05305-274-21-00
	4	Lock Nut, 1/4-20 SS	05310-374-01-00
8	1	Lower Wash Manifold	05700-003-78-40

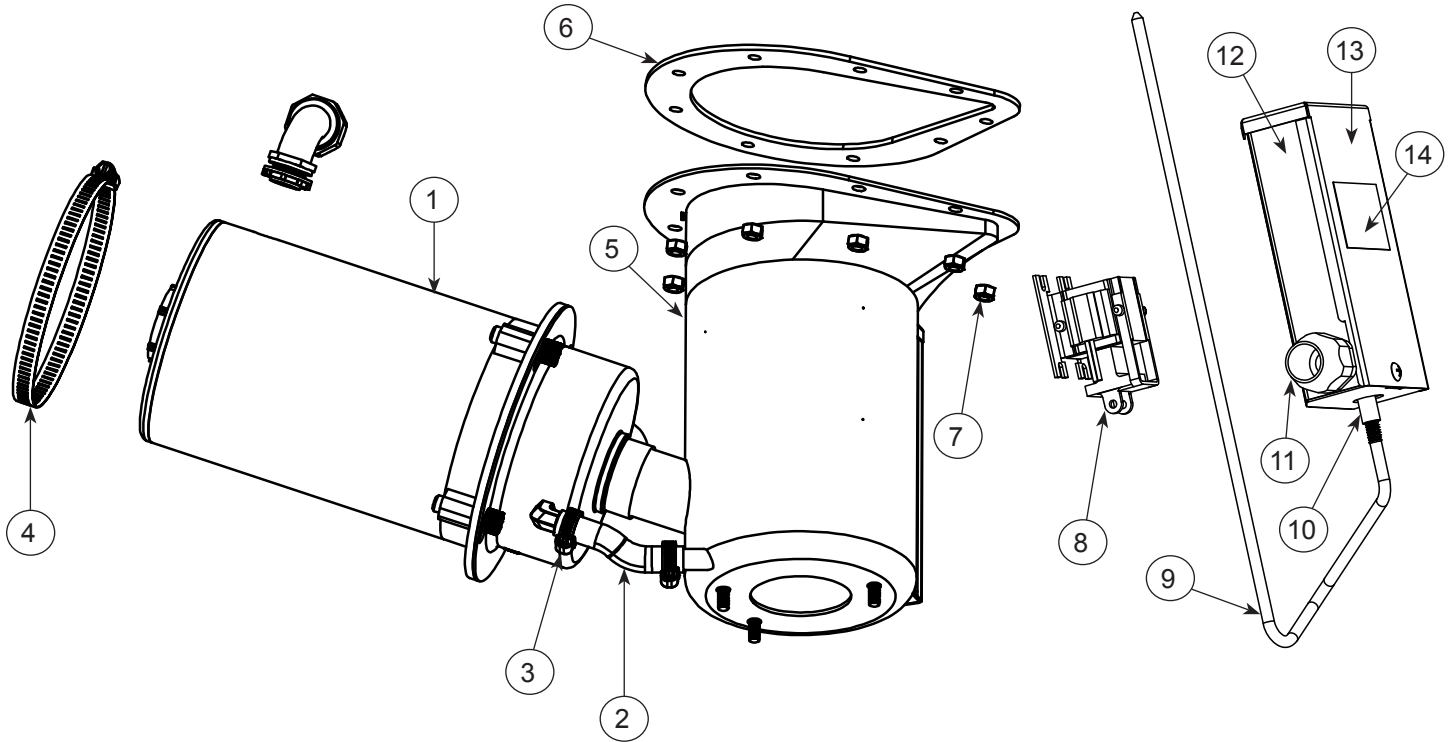

ITEM	QTY	DESCRIPTION	PART NUMBER
1	1	Pump and Motor Assembly	06105-004-24-80
2	1	Pump Drain Hose	05700-004-08-52
3	2	Clamp, 7/16" to 25/32"	04730-011-36-05
4	1	Clamp, 5 5/8" to 6"	04730-011-34-90
5	1	Sump Weldment	05700-003-78-41
6	1	Sump Gasket	05330-003-78-31
7	9	Lock Nut, 1/4-20 S/S	05310-374-01-00
8	1	Drain Solenoid, 115 V	04810-200-11-00
	1	Drain Solenoid, 208/230 V	04810-111-87-74
9	1	Drain Link	See next page.
10	1	Connection, Drain Link	See next page.
11	1	Fitting, 1/2" Plastic	05975-011-45-13
12	1	Box, Drain Solenoid	05700-003-78-46
13	1	Cover, Drain Solenoid	05700-003-78-48
14	1	Decal, Warning-Disconnect Power	09905-100-75-93

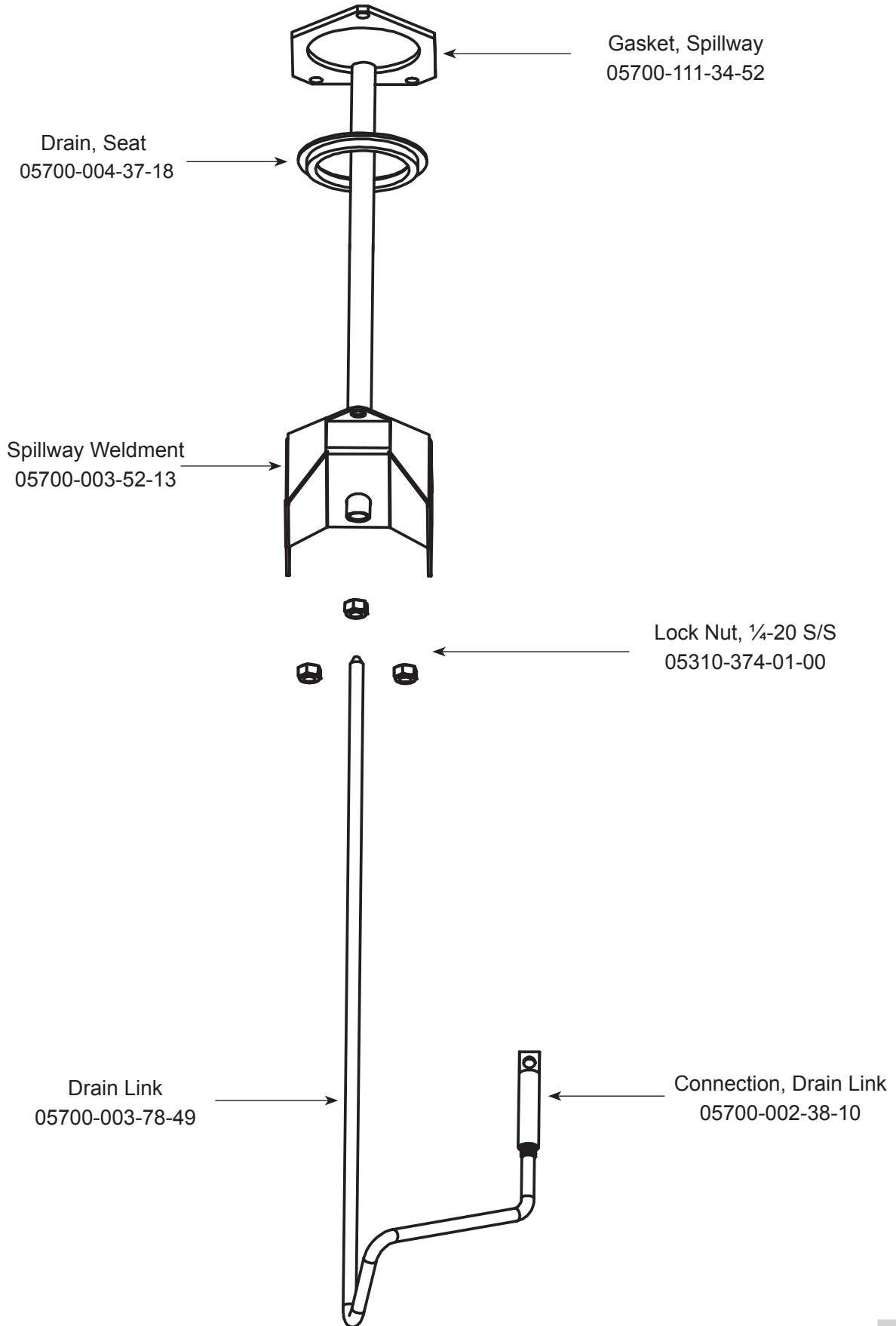

Complete Pump and Motor Assembly
06105-004-24-80

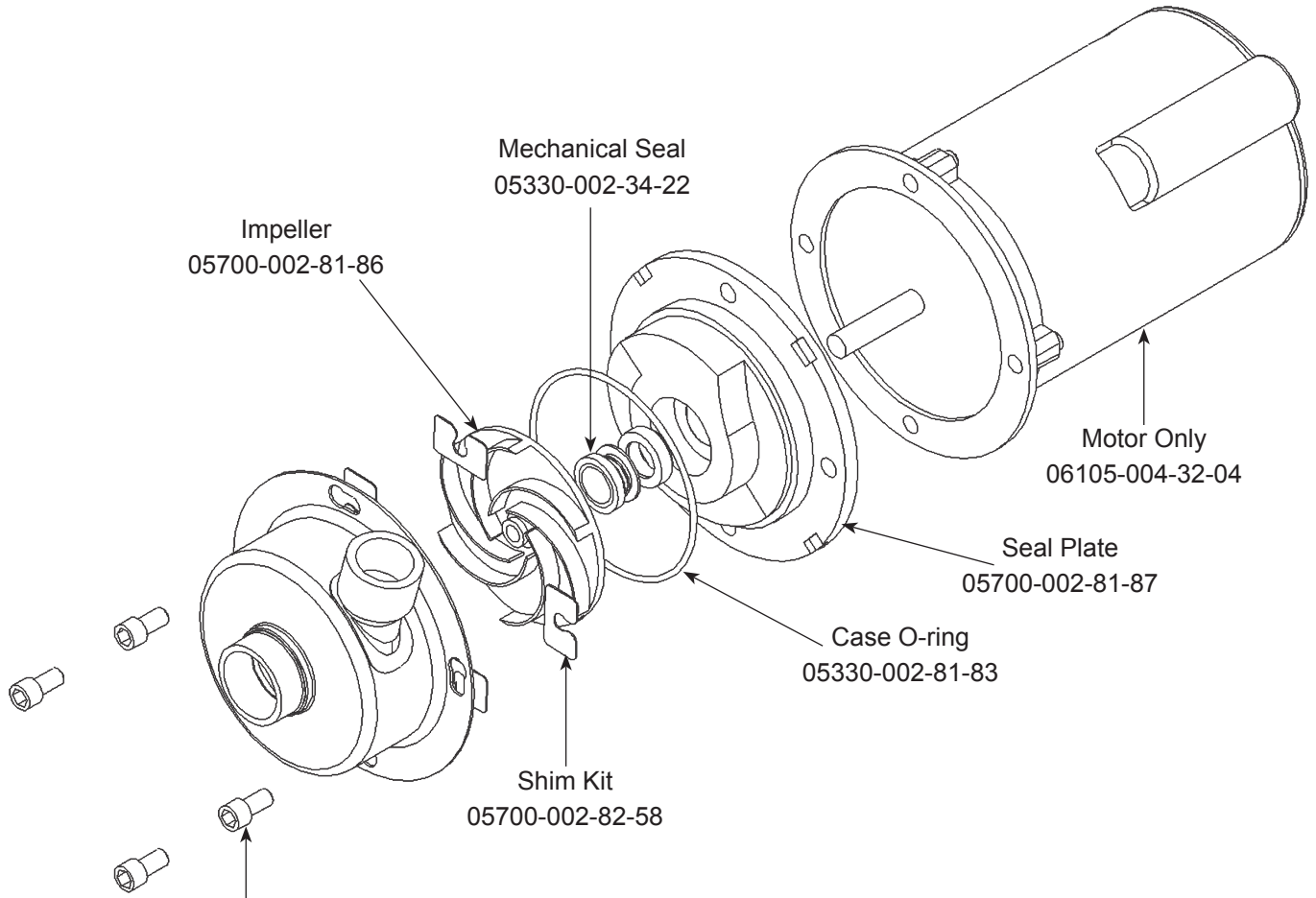

Case Cap Screw
05305-356-04-00

Mechanical Seal
05330-002-34-22

Impeller
05700-002-81-86

Motor Only
06105-004-32-04

Seal Plate
05700-002-81-87

Case O-ring
05330-002-81-83

Shim Kit
05700-002-82-58

Pump Discharge Hose
(not shown)
05700-003-78-50

Hose Clamp, 1 5/16" to 2 1/4" S/S
(not shown)
04730-719-18-00 (2 required)

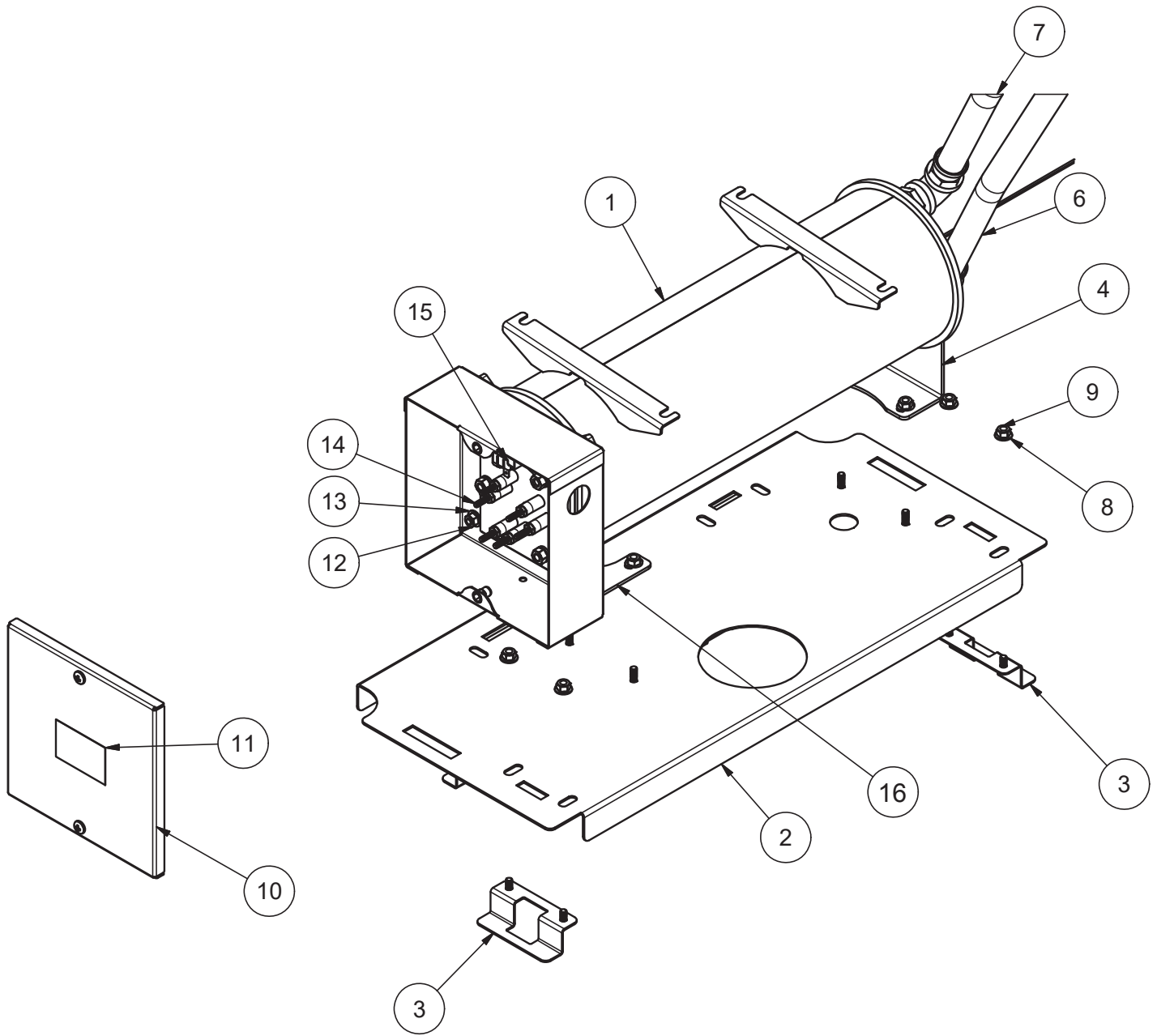

ITEM	QTY	DESCRIPTION	PART NUMBER
		Complete Booster Tank Assembly	05700-004-52-09
1	1	Booster Tank	05700-004-52-23
2	1	Plate, Booster Tank Base	05700-004-48-90
3	4	Bracket, Booster Mount	05700-004-48-83
4	1	Bracket, Booster Tank	05700-004-52-08
5	2	Plumbing, Booster Inlet/Outlet	05700-004-52-28
6	1	Hose, Blue 3/4" x 45"	05700-004-52-27
7	1	Hose, Red 3/4" x 49"	05700-004-52-26
8	16	Washer, 1/4-20	05311-174-01-00
9	16	Locknut, 1/4-20 Hex with Nylon Insert	05310-374-01-00
10	1	Cover, Booster Tank	05700-004-52-21
11	1	Decal, Warning-Disconnect Power	09905-100-75-93
12	6	Nut, Hex 5/16-18	05310-275-01-00
13	6	Lockwasher, Split, 5/16"	05311-275-01-00
14	1	Heater, Rinse	04540-121-47-40
14a	1	Gasket, Rinse Heater	05330-200-02-70
15	1	Thermostat, High Limit	05930-004-33-12
15a	1	Bracket, High Limit Thermostat	05700-004-36-84
16	1	Bracket, Booster Tank	05700-004-55-05

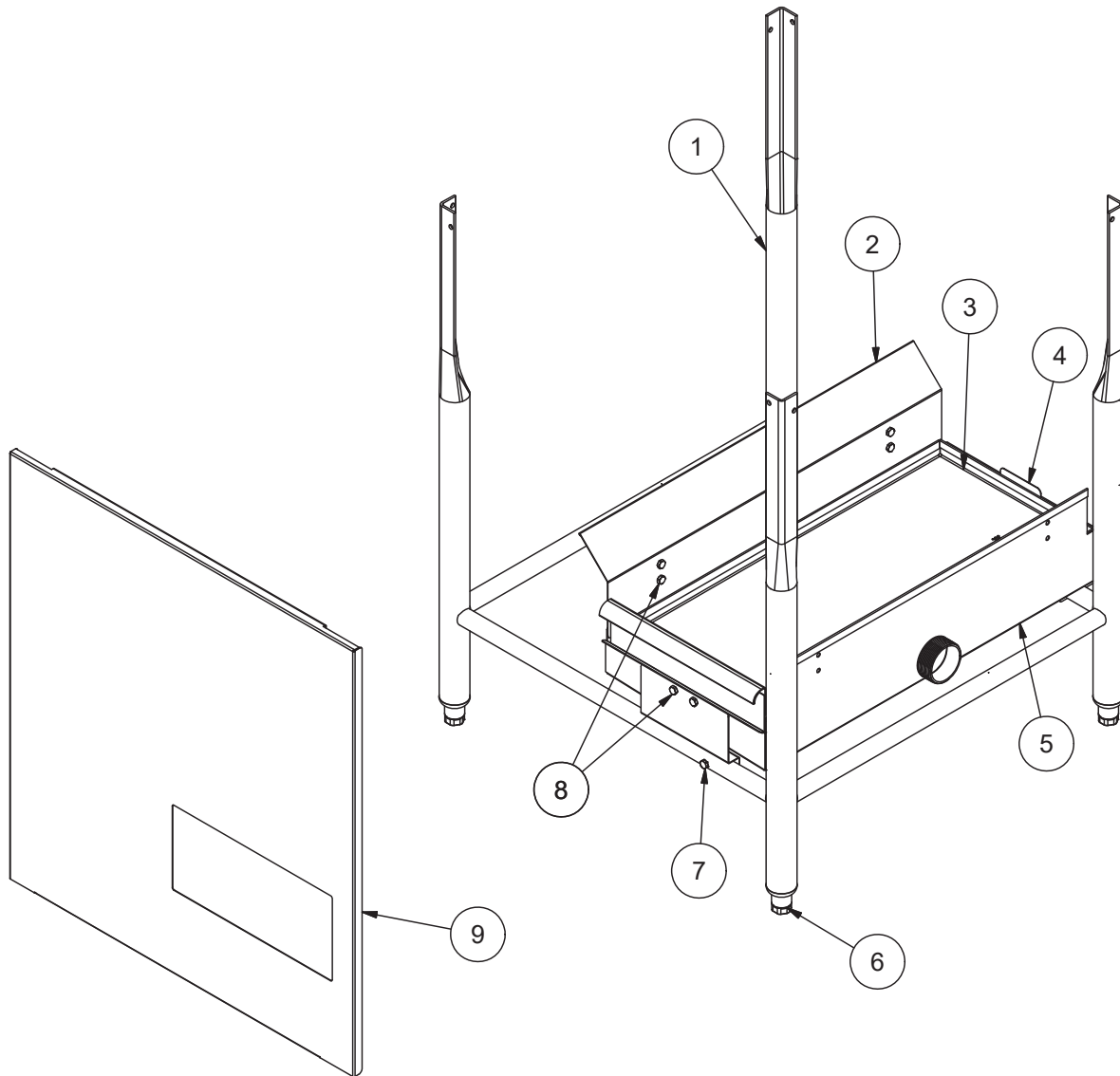

ITEM	QTY	DESCRIPTION	PART NUMBER
1	1	Frame Weldment	05700-003-78-38
2	1	Splash Shield	05700-004-01-54
3	1	Strainer	05700-004-09-08
4	1	Strainer Stop	05700-004-18-33
5	1	Accumulator	05700-004-08-39
6	4	Adjustable Foot	05340-108-01-03
7	1	Screw, 1/4-20 x 1 1/2"	05305-274-23-00
	1	Locknut, 1/4-20 (Not Shown)	05310-374-01-00
8	6	Bolt, 1/4-20 x 3/8"	05305-274-20-00
	6	Locknut, 1/4-20 Low Profile (Not Shown)	05310-374-02-00
9	1	Front Dress Panel	05700-004-08-71
		Front Dress Panel, I-E-LTH	05700-004-50-07

Parts not shown to scale in relation to each other.

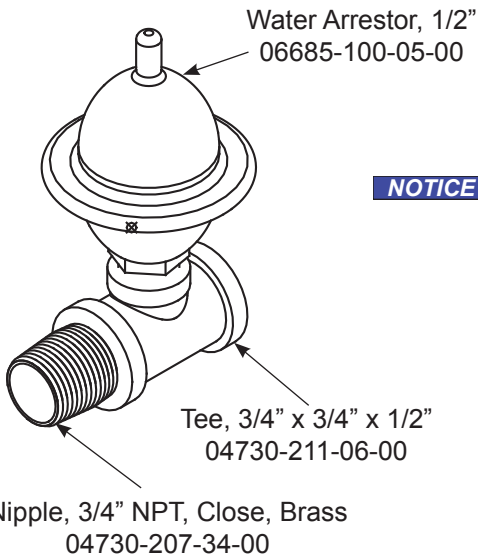
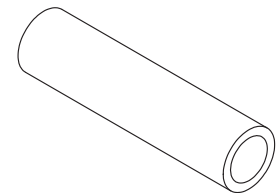
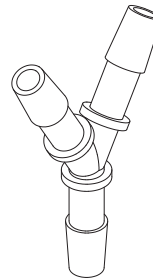
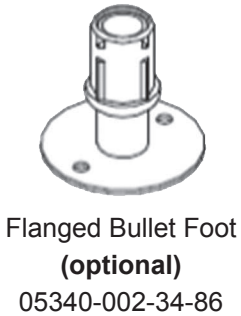
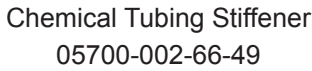
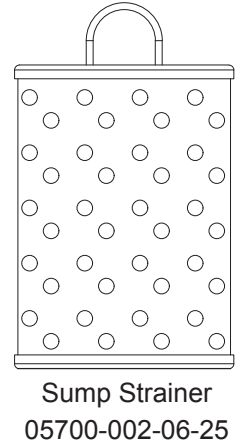
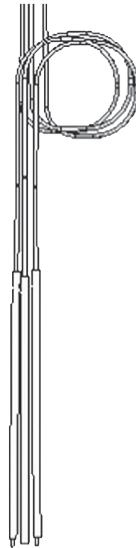
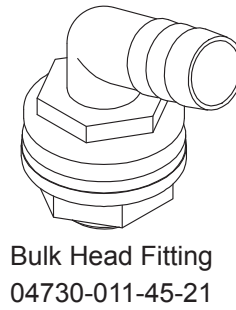
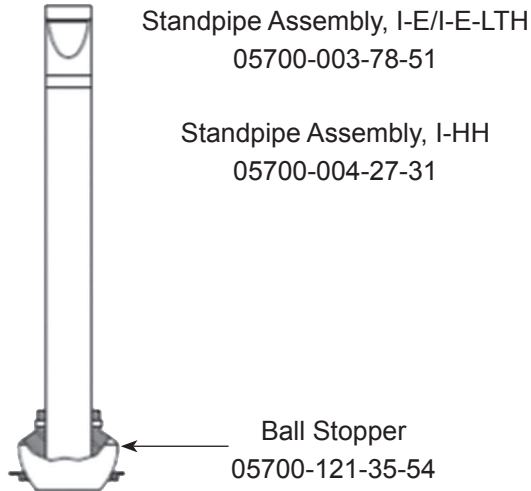

NOTICE Machines with serial numbers before 17C331529 have 1/2" plumbing. Click [here](#) to open the manual which shows the 1/2" plumbing.

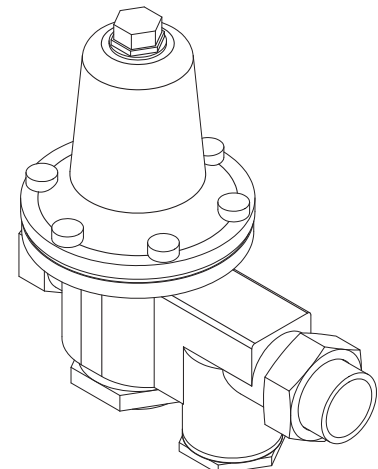

**NOBLE I-E ELETRICAL DIAGRAM
LADDER SCHEMATIC
115 VOLTS 60 HERTZ SINGLE PHASE**

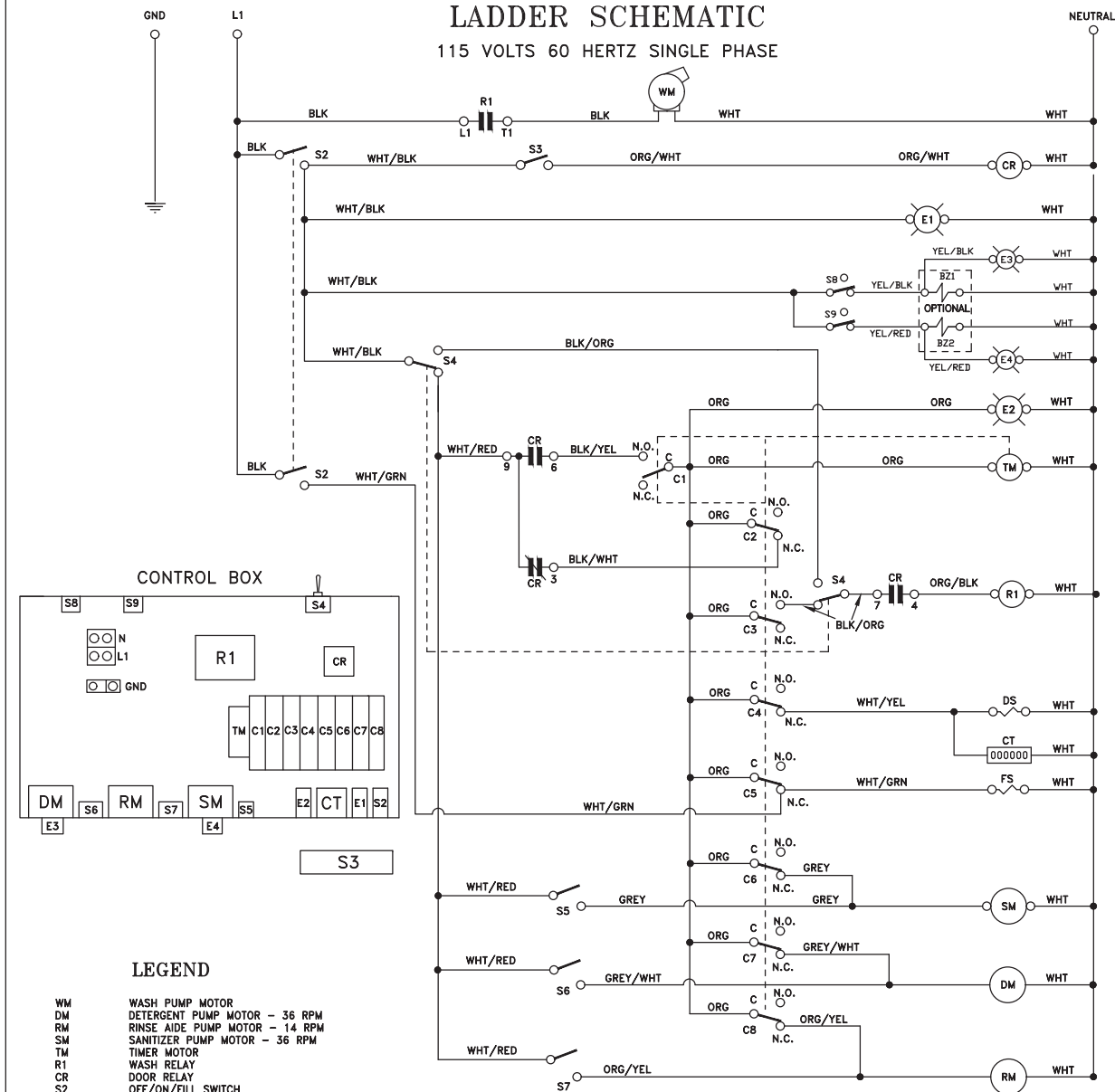

LEGEND

- WM WASH PUMP MOTOR
- DM DETERGENT PUMP MOTOR - 36 RPM
- RM RINSE AIDE PUMP MOTOR - 14 RPM
- SM SANITIZER PUMP MOTOR - 36 RPM
- TM TIMER MOTOR
- R1 WASH RELAY
- CR DOOR RELAY
- S2 OFF/ON/FILL SWITCH
- S3 DOOR SWITCH
- S4 DELIME SWITCH
- S5 SANITIZER PRIME SWITCH
- S6 DETERGENT PRIME SWITCH
- S7 RINSE AID PRIME SWITCH
- S8 DETERGENT VACUUM SWITCH
- S9 SANITIZER VACUUM SWITCH
- E1 POWER LIGHT
- E2 CYCLE LIGHT
- E3 DETERGENT LIGHT
- E4 SANITIZER LIGHT
- DS DRAIN SOLENOID
- FS FILL SOLENOID
- C1 CYCLE MICROSWICH
- C2 AUTOSTART RESET MICROSWICH
- C3 WASH MICROSWICH
- C4 DRAIN MICROSWICH
- C5 FILL MICROSWICH
- C6 SANITIZER MICROSWICH
- C7 DETERGENT MICROSWICH
- C8 RINSE ADDITIVE MICROSWICH
- CT COUNTER
- BZ1 DETERGENT BUZZER
- BZ2 SANITIZER BUZZER

TIMING CHART

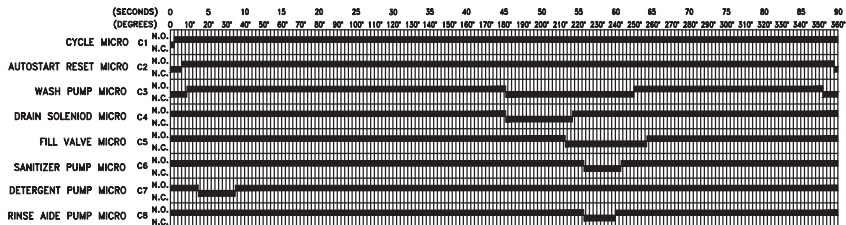

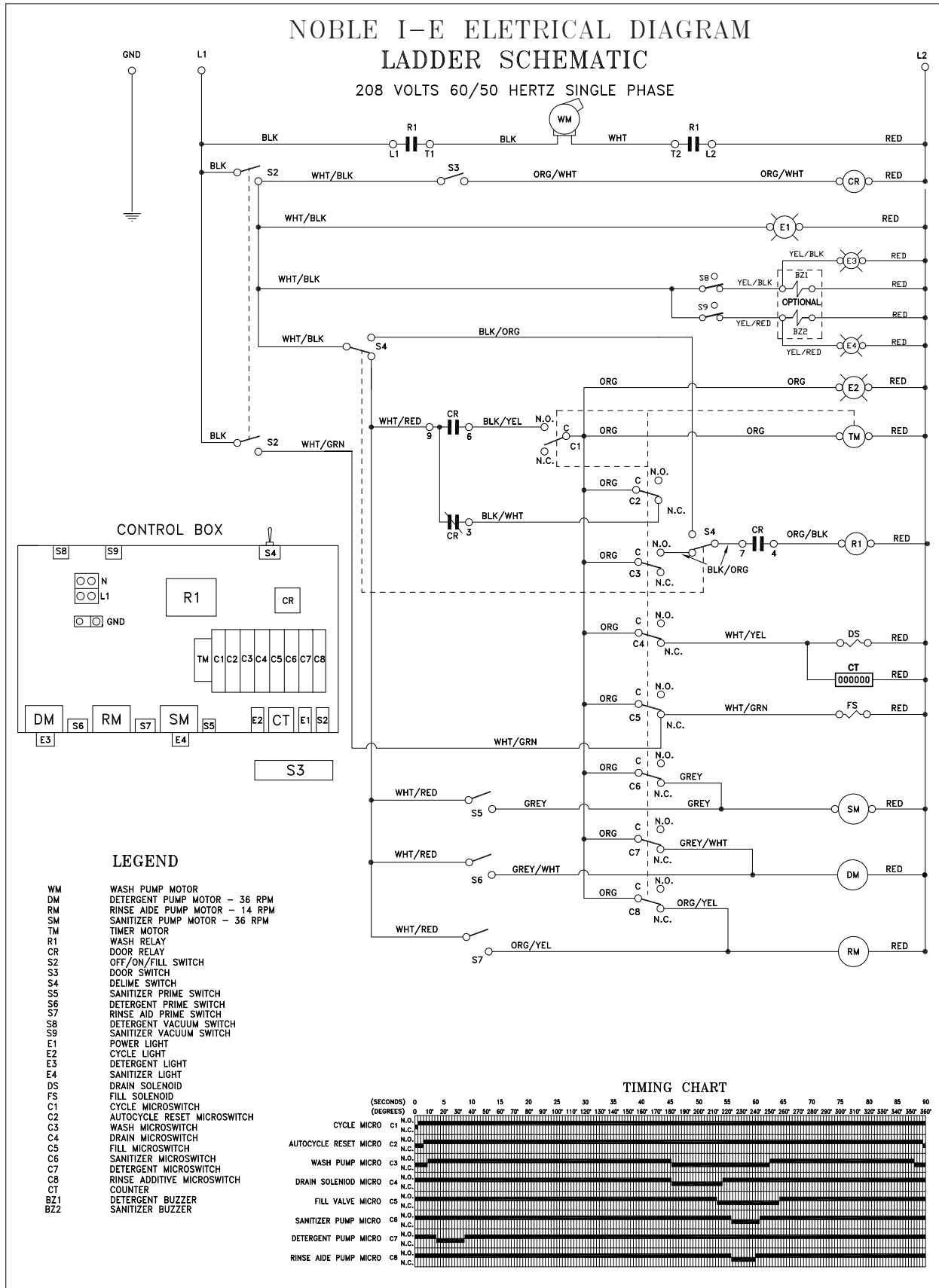

NOBLE I-E-LTH
SCHEMATIC

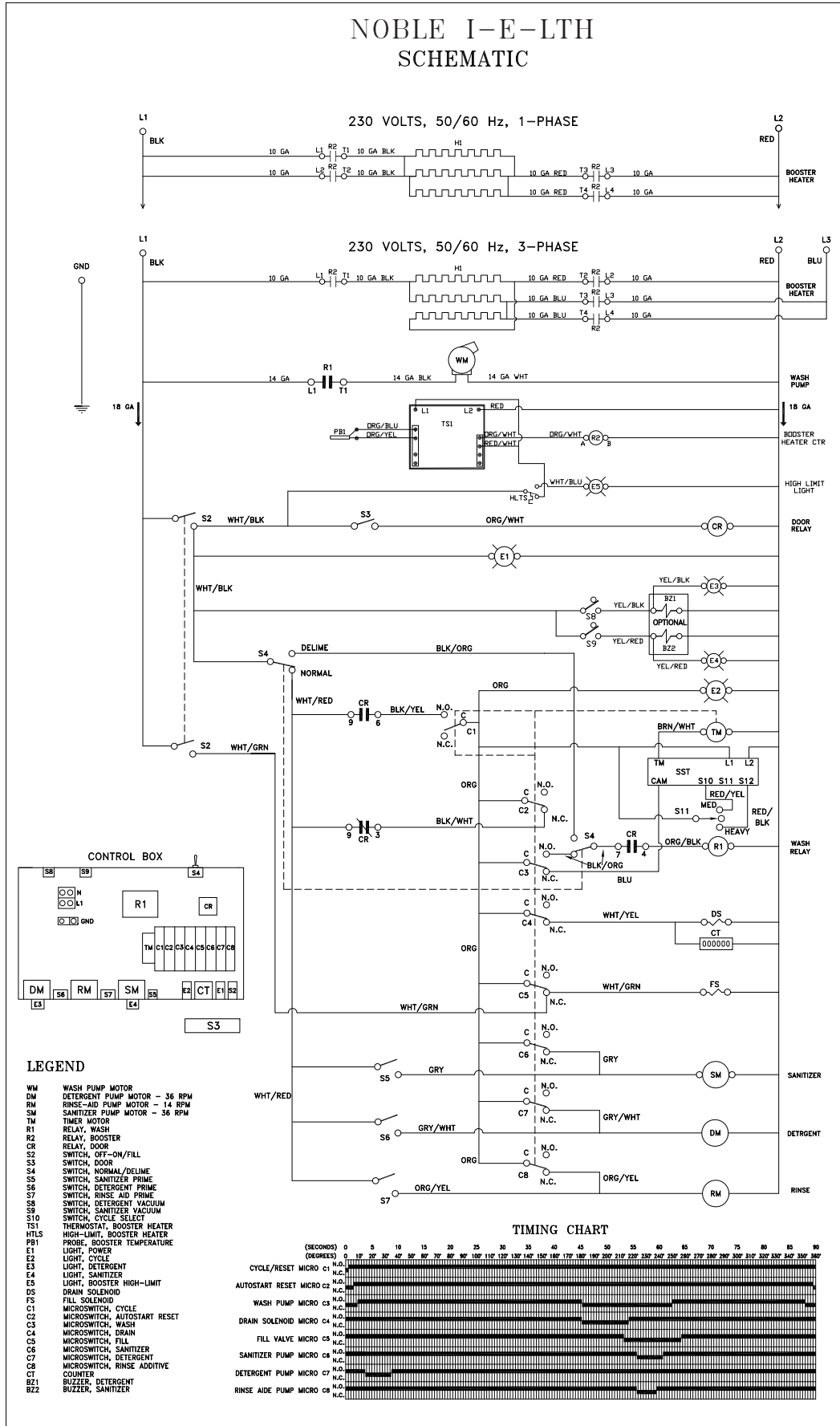



Noble Warewashing • Lancaster, Pennsylvania
www.nobleproducts.biz
For Service Call 1-888-800-5672